

Beam Shelf 5

Assembly guide

Components

Place the components on a blanket to avoid scratches on the floor and on the product.

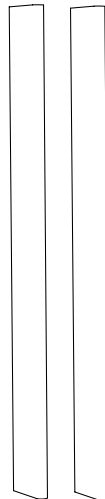
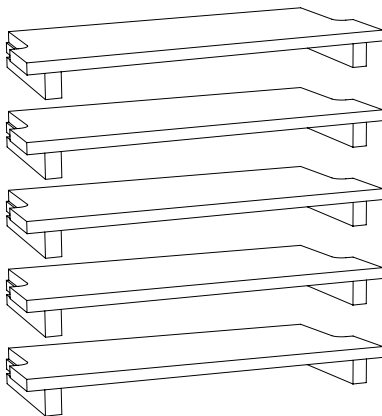
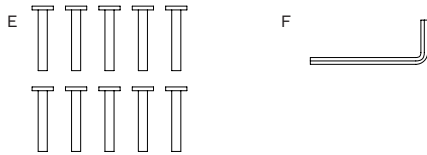
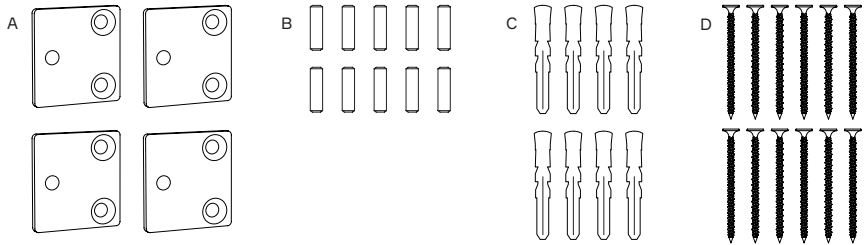

Step 1

Place the side rails on the ground, ensuring they are oriented correctly. Use a screwdriver or drill to attach the hinges (A) to the side rails with the long screws (D).

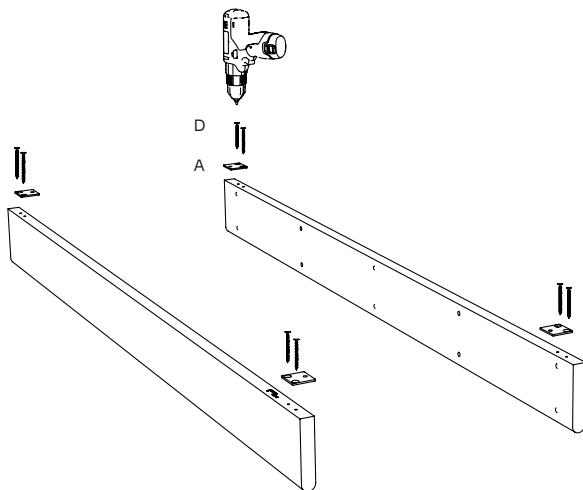

Step 2

Insert the six middle dowels (B) into the holes closest to the hinges on both side rails.

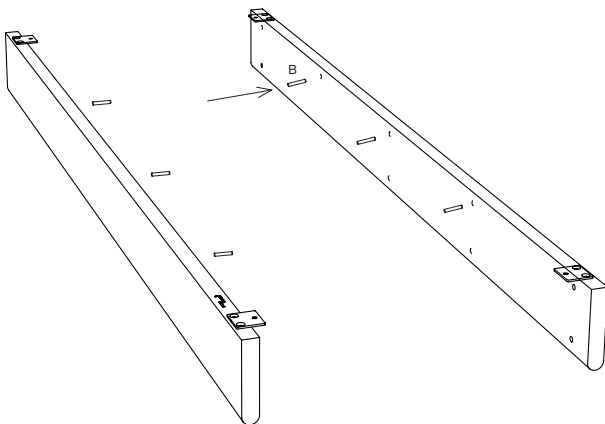

Step 3

Turn the side rails so the hinges face down towards the ground. **IMPORTANT NOTE:** Be aware that the marking "right" on the side panel is positioned downward to the right where the bottom shelf is to be attached to the panel, and that the marking "left" on the other side panel is positioned downward to the left. Then slide the three middle shelves between the side rails, ensuring the dowels fits into the slots on the shelf.

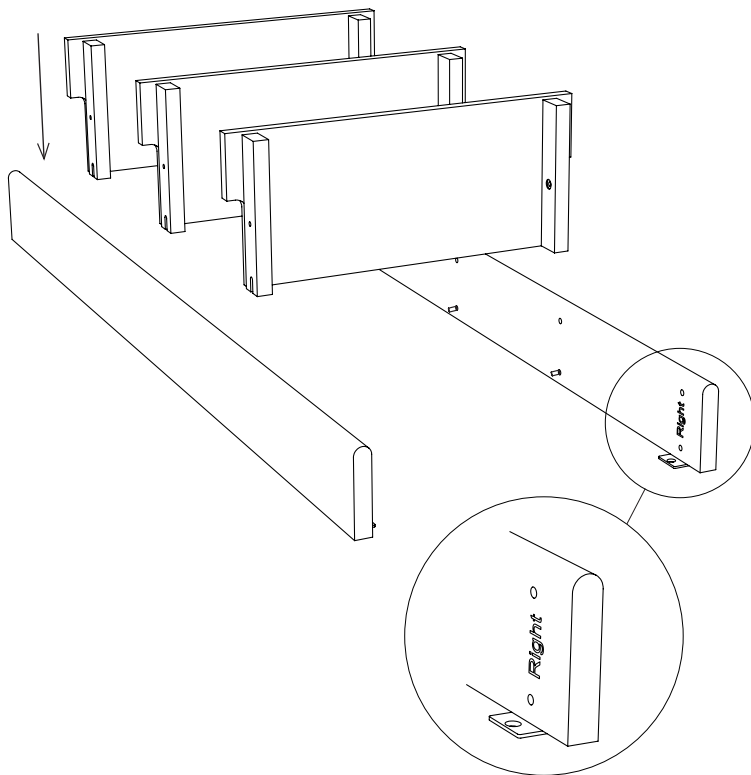

Step 4

Secure the shelves to the side rails by screwing the short screws (E) through the hole in the shelves and into the side rails using the allen key (F).

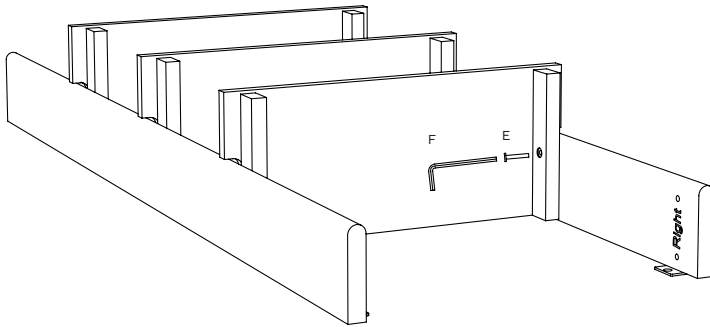

Step 5

Hold the shelving unit in place where it is to be mounted. Place a spirit level on a shelf to ensure it is straight. Use a pencil to mark through the holes in the hinges where to drill on the wall.

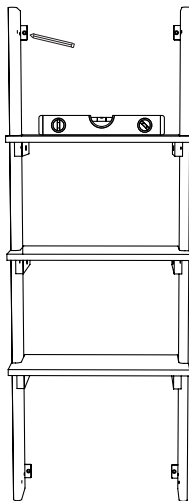

Step 6

Remove the shelving unit. Use a drill to create holes at the marked spots on the wall, then insert a wall plug (C) into each hole.

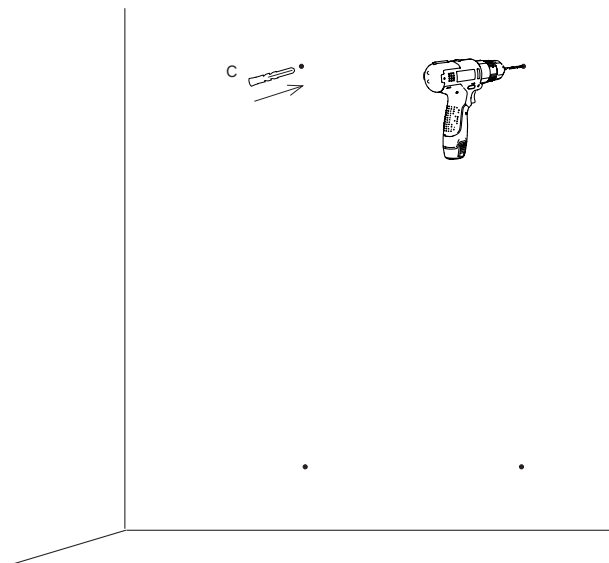

Step 7

Place the shelving unit on the wall and secure it using the four brackets (A) and the long screws (D).

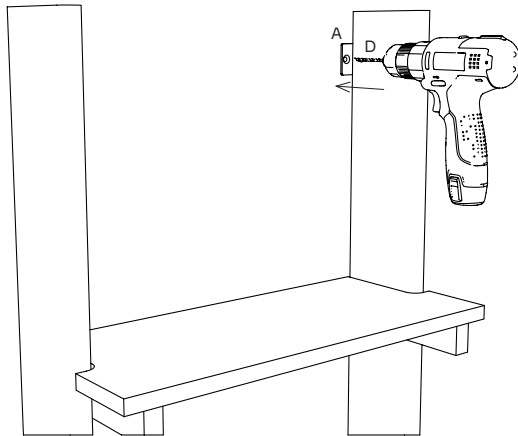

Step 8

Then insert the four last dowels (B) into the holes on both side rails where the top and bottom shelves are to be mounted. Then slide the two remaining shelves between the side rails, ensuring the dowels fits into the slots on each shelf.

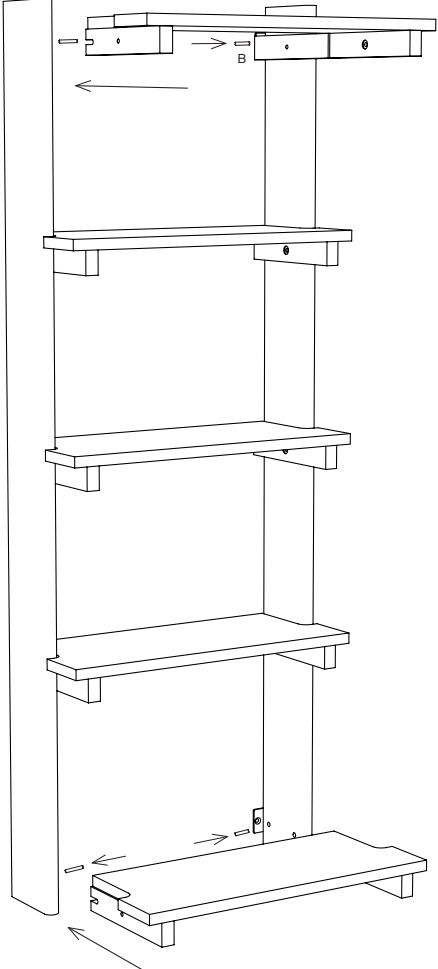

Step 9

Secure the shelves to the side rails by screwing the short screws (E) through the holes in the shelves and into the side rails using the allen key (F).

Important: Screws may loosen over time due to use or vibration. Check and tighten them regularly to maintain stability. We recommend re-tightening (but not over-tightening) the screws approximately every six months. This helps your furniture stay stable and maintain its quality for years to come.

