

## Beam Bench

---

Assembly guide

### Components

Place the components on a blanket to avoid scratches on the floor and on the product.

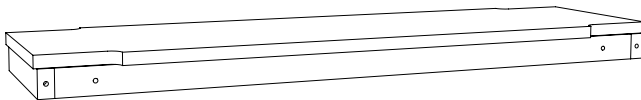
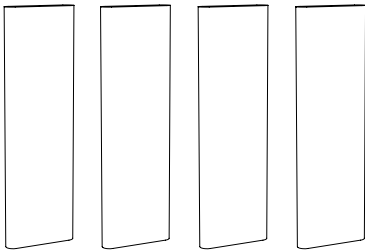
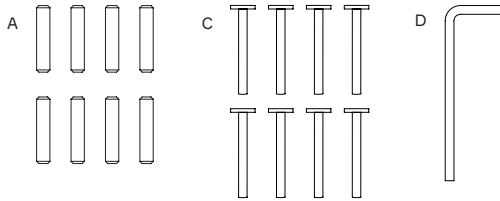

### Step 1

Place one panel flat on the ground with the bottom facing up. Insert the dowels (A) into the outermost holes, then attach two of the four legs by sliding them onto the dowels on the same side.

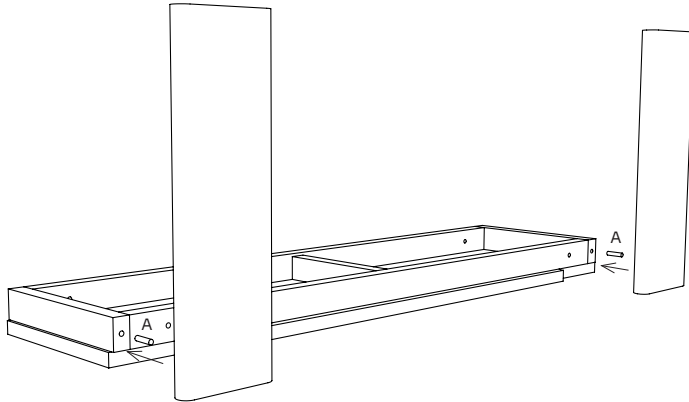

### Step 2

Secure the legs using the allen key (D) and the screws (C).

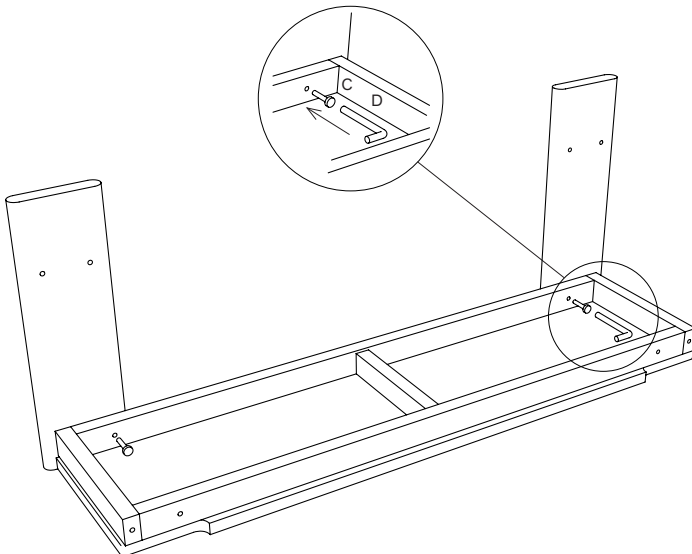

### Step 3

Carefully turn the bench onto its side so it rests on the legs. Insert the dowels into the outermost holes on the two attached legs. Gently lower the next panel onto the dowels and gently push it into place.

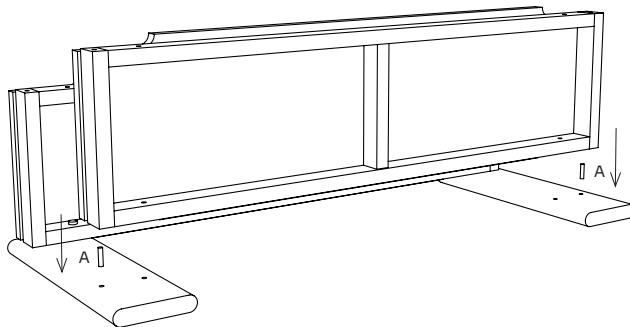

### Step 4

Secure the panel using the allen key (D) and screws (C).

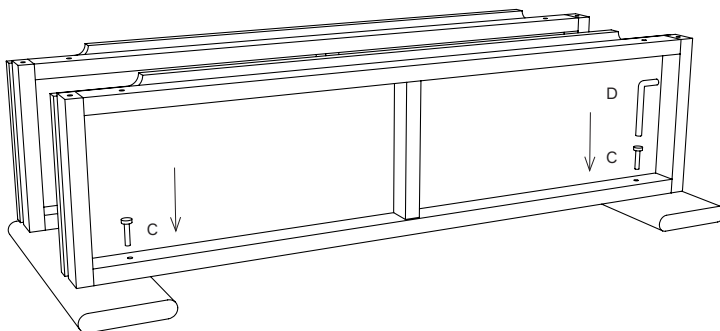

### Step 5

Insert the dowels (A) into the remaining outermost holes. Attach the two remaining legs by sliding them onto the dowels (A).

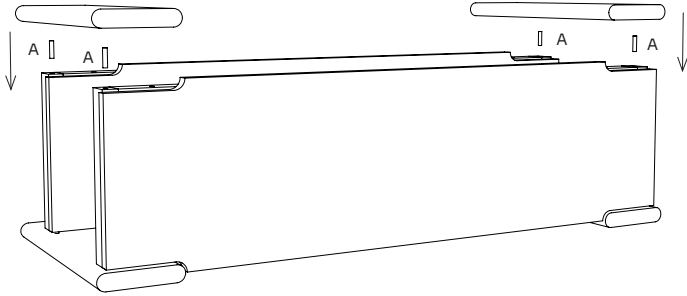

### Step 6

Carefully turn the bench around. Secure the legs using the allen key (D) and screws (C).

**Important:** Screws may loosen over time due to use or vibration. Check and tighten them regularly to maintain stability. We recommend re-tightening (but not over-tightening) the screws approximately every six months. This helps your furniture stay stable and maintain its quality for years to come.

