

ETHIMO

www.ethimo.com

dal colore ai colori



An aerial photograph of a vast lavender field. The rows of purple flowers are interspersed with green foliage. Three large patio umbrellas are scattered across the field: a light blue one in the top right, a lime green one in the middle right, and a dark blue one in the bottom left. A semi-transparent blue rectangular box is centered over the image, containing white text.

THE ITALIAN
STYLE FOR
OUTDOOR
LIVING



ETHIMO

Azienda italiana creativa, brillante interprete del fascino e della tradizione mediterranea, Ethimo propone una collezione di arredi outdoor per vivere all'aperto con stile ed eleganza.

Ispirato dalle suggestioni e dai colori dei paesaggi italiani, il team creativo, cuore pulsante dell'azienda, coglie e promuove un modo contemporaneo di vivere l'esterno, un autentico "italian style for outdoor living" che coniuga l'estetica e il design delle collezioni con le esigenze di comfort e praticità della vita all'aria aperta.

Il profondo know-how di Ethimo nel settore dell'arredo da esterno è garanzia di qualità dei materiali selezionati e delle soluzioni all'avanguardia adottate nei processi costruttivi.

Il design caldo ed essenziale delle linee è sintesi tra ricerca di contemporaneità e reinterpretazione di forme classiche che rendono l'elemento d'arredo nuovo e familiare al tempo stesso. Prodotti attuali con una tradizione alle spalle.

La collezione presenta una palette di colori ispirata ai paesaggi italiani, con le sfumature di verde della Toscana e delle Langhe, gli azzurri intensi del Mediterraneo e il bianco puro delle isole del Sud, i colori vivaci dei giardini fioriti di Capri e della Sicilia, luoghi in cui la natura è protagonista e contamina con la forza della bellezza stili ed architetture.

Ethimo porta il design italiano nei luoghi più belli del mondo, per ricreare ovunque il fascino dell'Italian style.

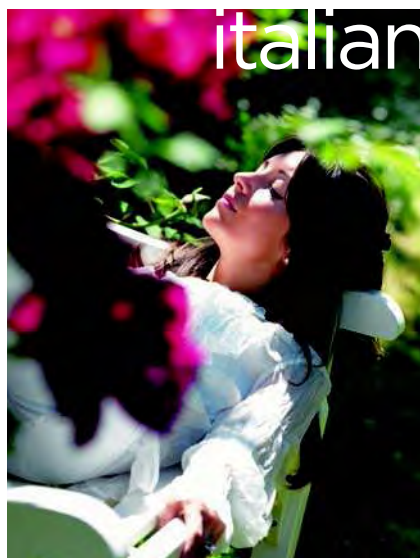

ETHIMO

A creative Italian company which brilliantly interprets classic Mediterranean tradition and charm, Ethimo presents a collection of outdoor furniture for a stylish, elegant approach to open-air living.

Inspired by the atmospheres and colours of Italian landscapes, the creative team (and life force of this firm), embraces and promotes a contemporary, authentic "italian style for outdoor living", combining the styling and design of our collections with the comfort and practicality that's so essential for the alfresco lifestyle.

Ethimo's extensive know-how in the garden furniture sector ensures that the materials selected and the innovative solutions used in its manufacturing process are of the highest quality.

The warm yet simple design of its products is achieved by blending contemporary styling with the reinterpretation of classical forms, making this furniture both fresh and familiar at the same time. Products with a story behind and a future ahead.

This collection presents a colour palette inspired by Italian landscapes. It features the various greens of Tuscany and the Langhe hills, the intense blues of the Mediterranean, and the pure white of the islands in the South, not to mention the bright hues of the gardens of Capri and Sicily in full bloom: places where nature reigns supreme, overwhelming local styles and architecture with the full force of its beauty.

Ethimo takes Italian design to the most beautiful places in the world, recreating the charm of the Italian style far and wide.





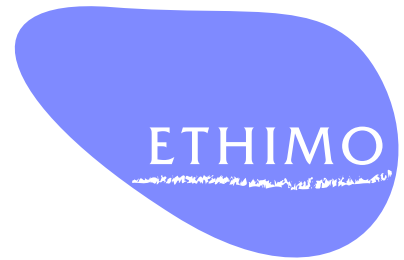

INDICE

TEAK DECAPATO/ PICKLED TEAK

COSTES P 6 / 115

LIGHTWICK

INFINITY P 12 / 116

METALLO / METAL

TAPISSERIE P 20 / 120

SUMMER P 22 / 121

FLOWER P 26 / 123

ELISIR P 36 / 126

CLESSIDRA P 40 / 128

TEAK E COLORE / TEAK AND COLOUR

ESSENZA P 42 / 129

VILLAGE P 48 / 131

CRONOS P 52 / 134

FRIENDS P 54 / 135

MYA / 135

AMBRA / 136

STELLA P 58 / 136

ECLIPSE / 142

NOTTING HILL P 60 / 137

CRUISE P 62 / 138

PETIT CLUB P 65 / 139

CLUB P 65 / 139

ELÌT P 66 / 140

SAND P 70 / 141

SANDY P 72 / 141

ELLE P 73 / 140

SAHARA P 74 / 142

ETWICK

PHORMA P 76 / 143

LOTO P 78 / 147

ROYAL P 80 / 144

CUBE P 84 / 145

MOON P 88 / 147

TIME P 90 / 148

OMBRA / SHADE

FREE P 92 / 150

DEHORS / 149

LIBERTY / 152

HOLIDAY P 94 / 153

CLASSIC P 95 / 154

SQUARE P 96 / 156

FIORIERE / PLANTERS

FLAIR P 98 / 157

MATÌ P 99 / 157

LUCE / LIGHTINGS

GINGER P 100 / 158

STEP P 102 / 159

TOUR P 103 / 159

COMPLEMENTI /

COMPLEMENTS P 104 / 160

MATERIALI /

MATERIALS P 106

TEAK DECAPATO salotto / PICKLED *TEAK lounge*

COSTES













LIGHTWICK salotto modulare, chaise longue, lettino, tavoli e sedie

LIGHTWICK modular seating sofa, daybed, sun lounger, tables and chair

INFINITY





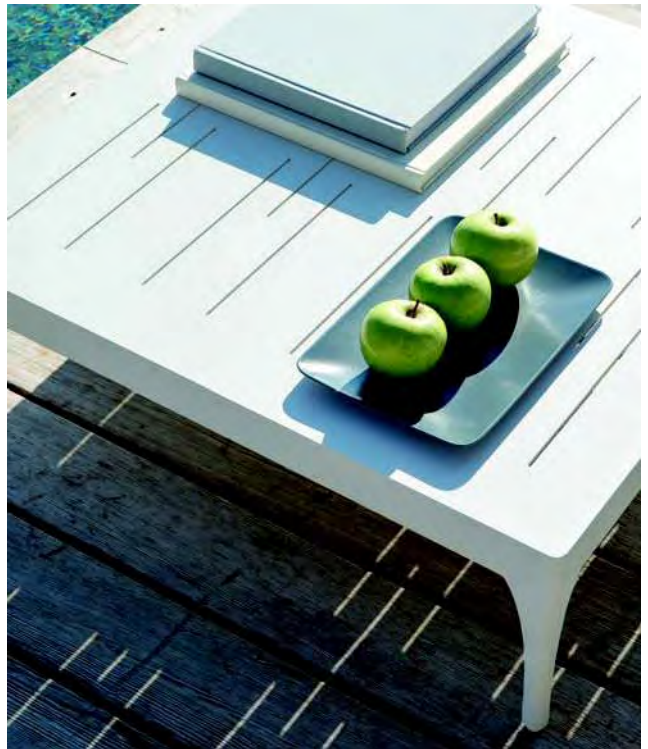





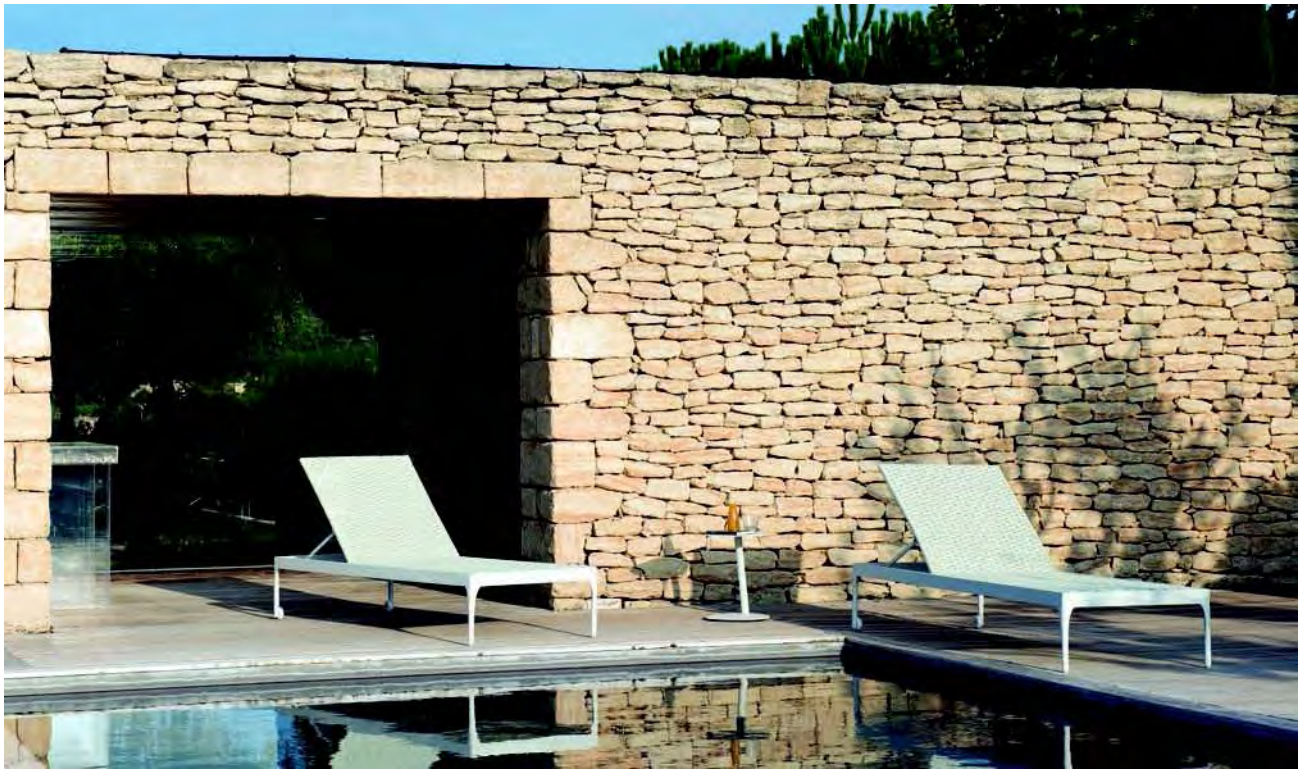





METALLO salotto / *METAL lounge*

TAPISSERIE

Designed by
Alessandra Baldereschi





METALLO tavoli e sedie

METAL tables and chairs

SUMMER









METALLO tavoli, sedie e prendisole

METAL tables, chairs and sunbed

FLOWER













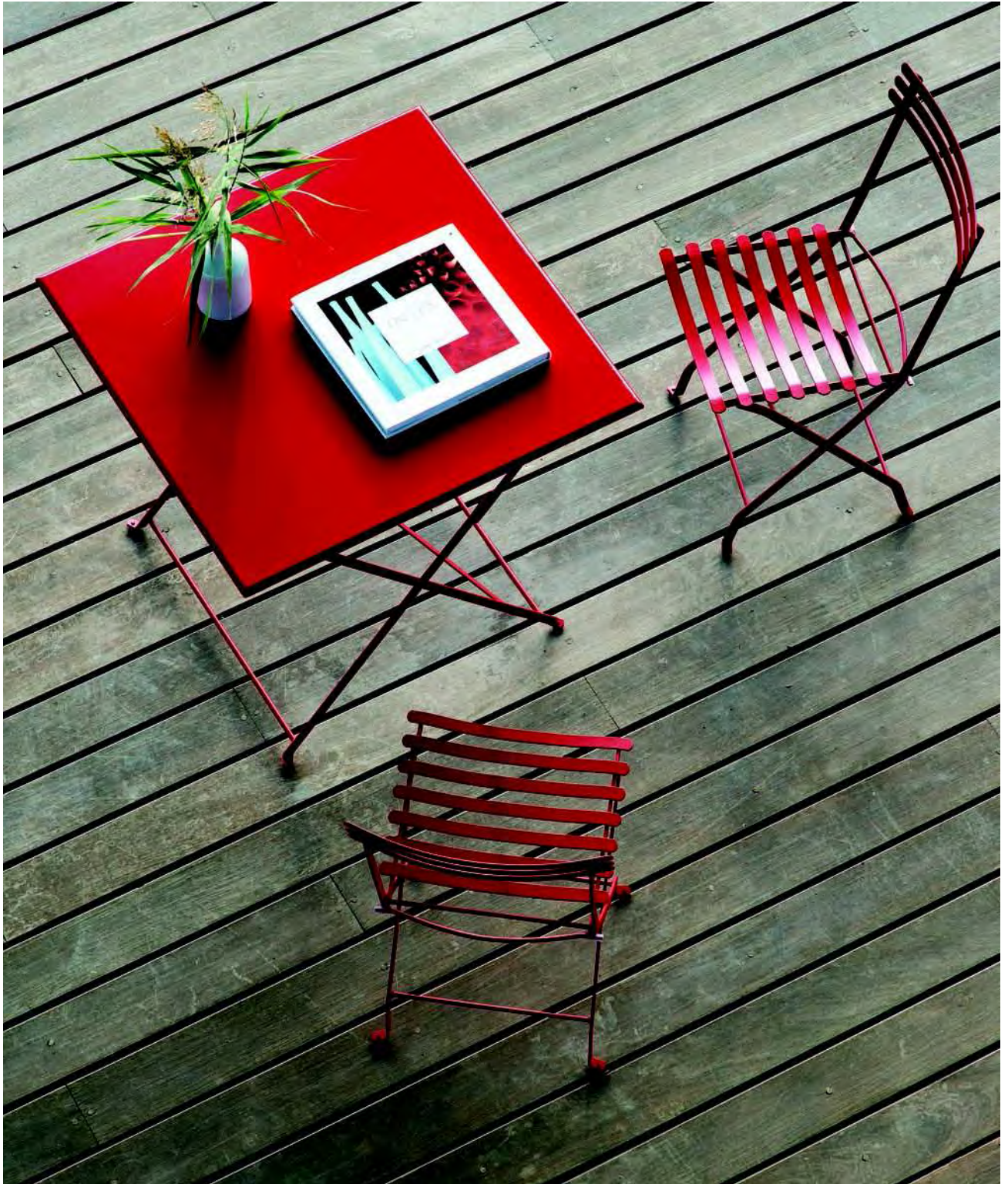







METALLO tavoli, sedie e prendisole
METAL tables, chairs and sunbed

ELISIR

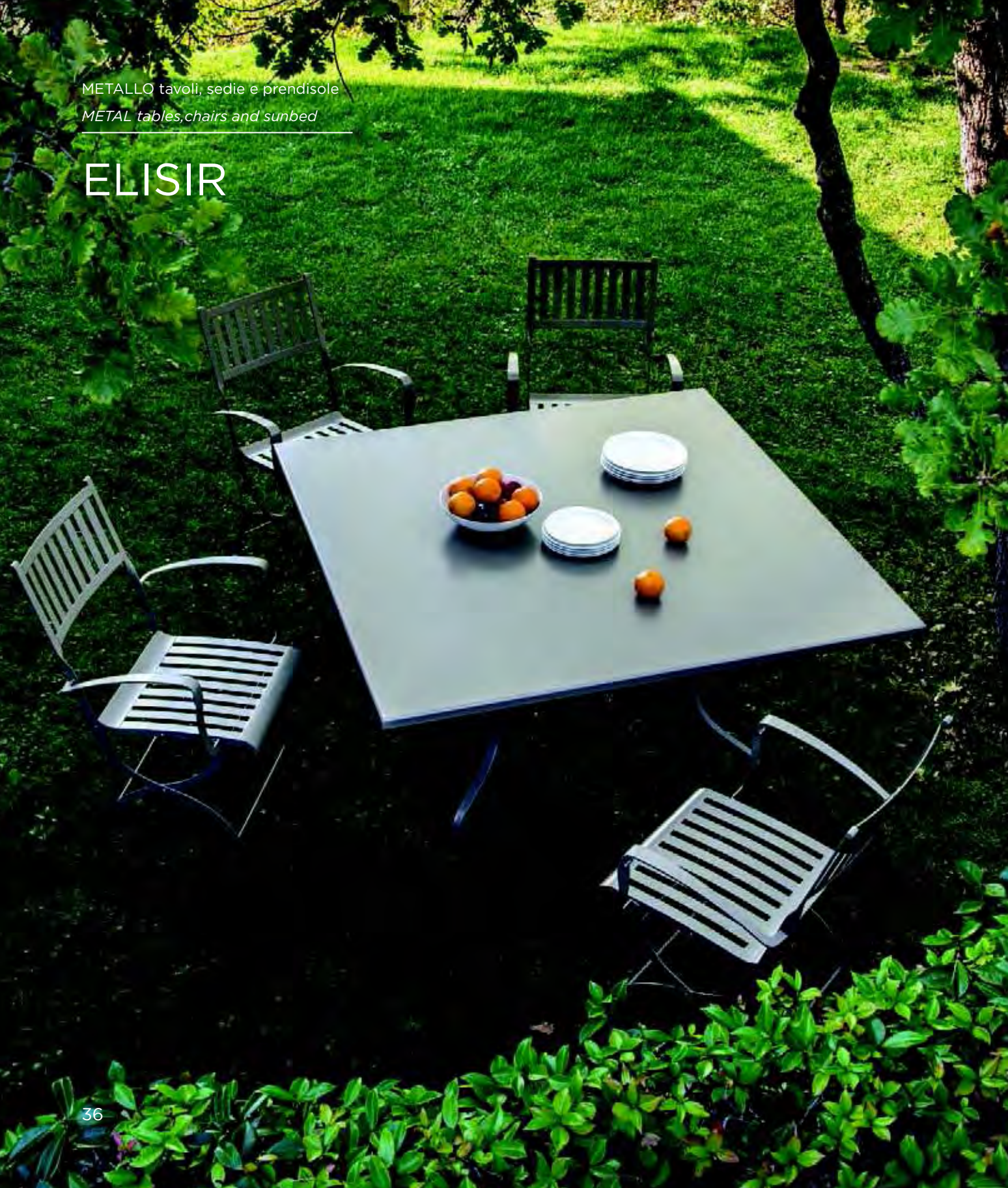







METALLO salotto / *METAL lounge*

CLESSIDRA





TEAK tavolo, sedie e prendisole / *TEAK table, armchair and sun lounger*

ESSENZA













TEAK salotto, tavolo, sedia e panca / *TEAK lounge, table, chair and bench*

VILLAGE









TEAK tavoli / *TEAK tables*

CRONOS





TEAK tavoli / *TEAK tables*

FRIENDS









TEAK sedie / *TEAK chairs*

STELLA





TEAK panche / *TEAK benches*

NOTTING HILL





TEAK chaise longue / TEAK deck chair

CRUISE







TEAK tavolini / *TEAK coffee table*

PETIT CLUB

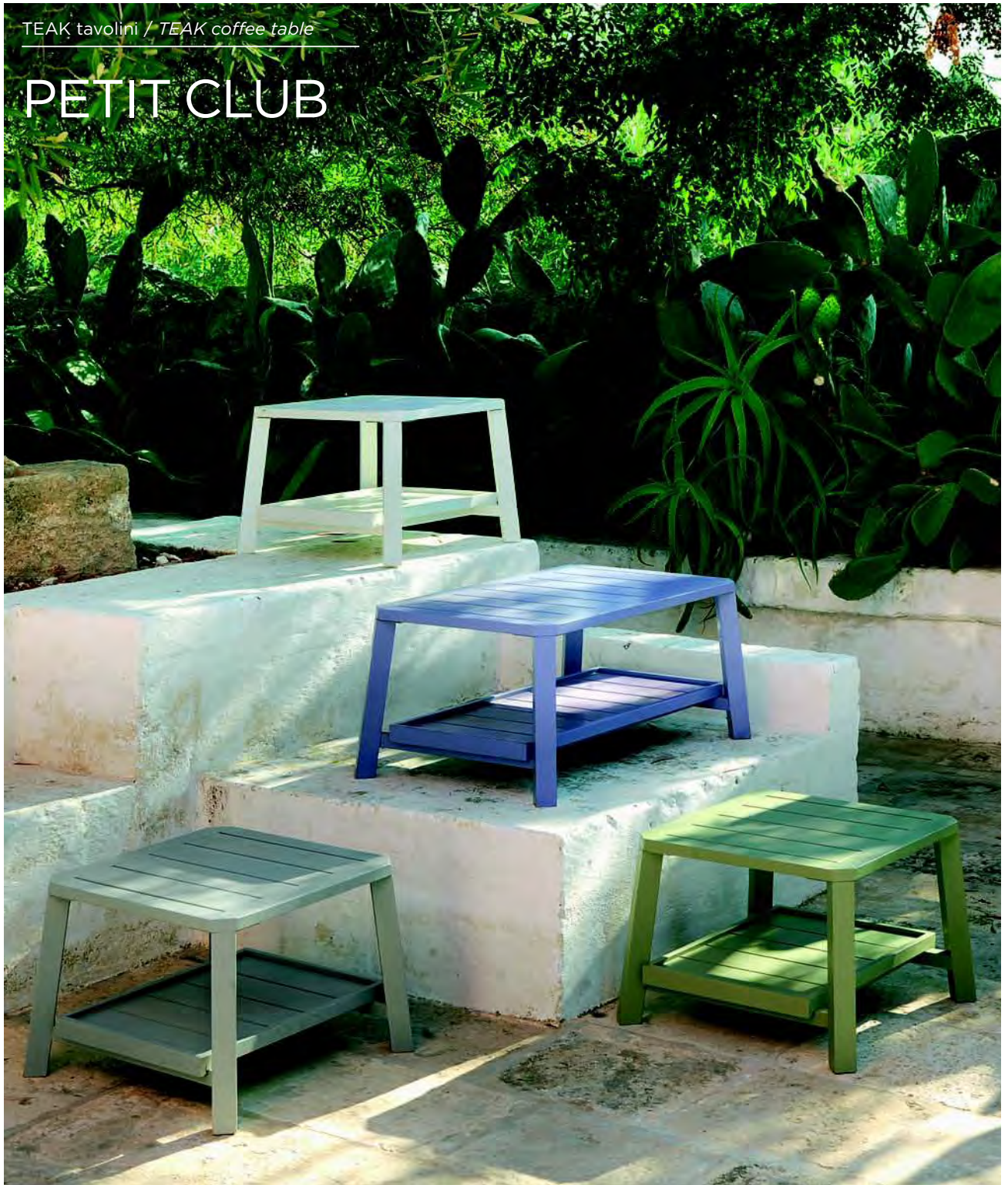

TEAK prendisole / TEAK sunbed

ELÌT



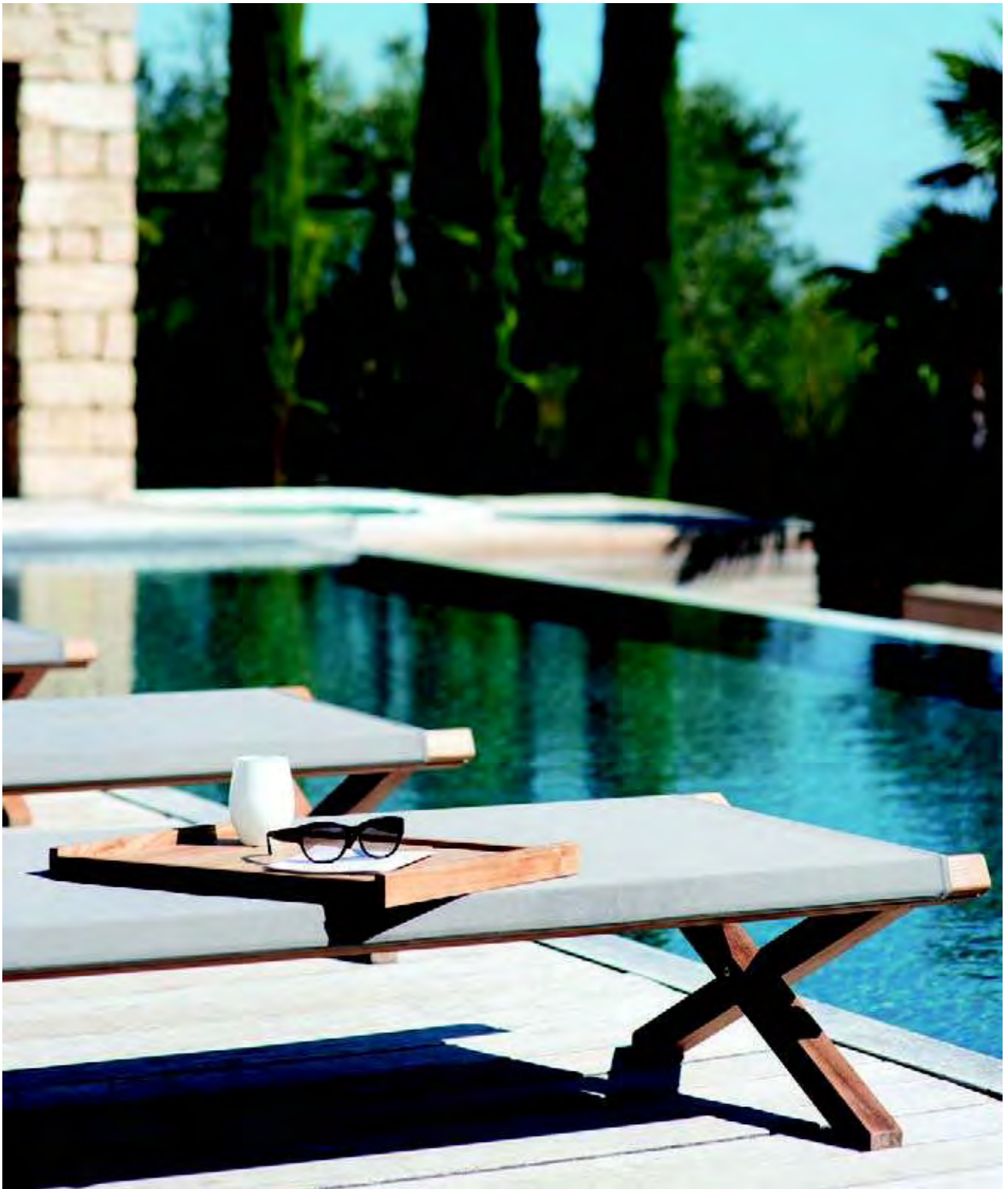





TEAK prendisole / *TEAK sunbed*

SAND





TEAK prendisole / *TEAK* backrest

SANDY



TEAK sdraio / *TEAK deck chair*

ELLE

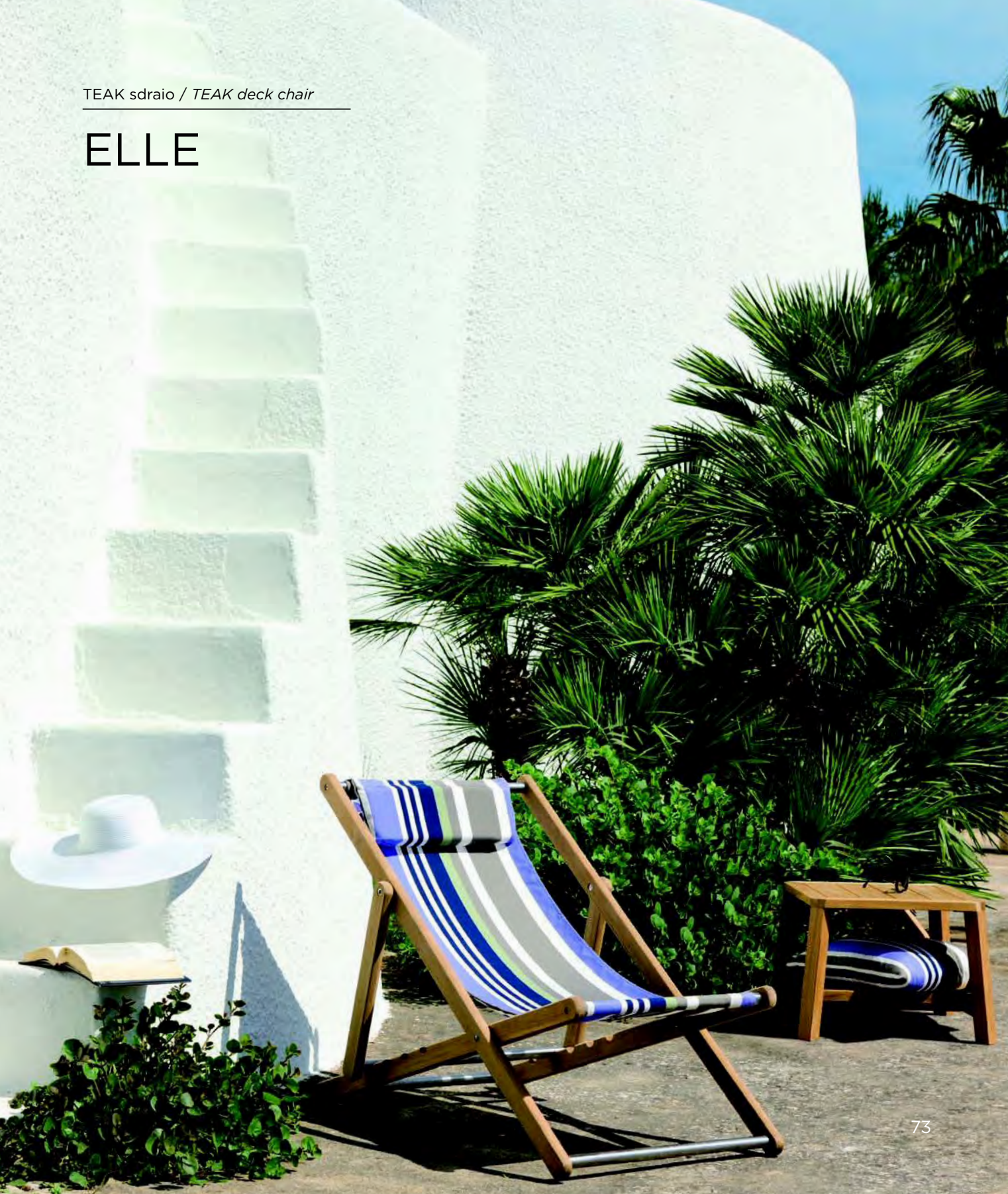

TEAK prendisole / *TEAK sun lounger*

SAHARA







ETWICK salotto / *ETWICK lounge*

PHORMA







ETWICK solotto / *ETWICK lounge*

ROYAL











ETWICK salotto / *ETWICK lounge*

CUBE







MOON





ETWICK tavolo e poltroncina

ETWICK table and armchair

TIME





FREE





OMBRA ombrelloni / SHADE parasols

HOLIDAY



CLASSIC



OMBRA gazebo / SHADE structure

SQUARE

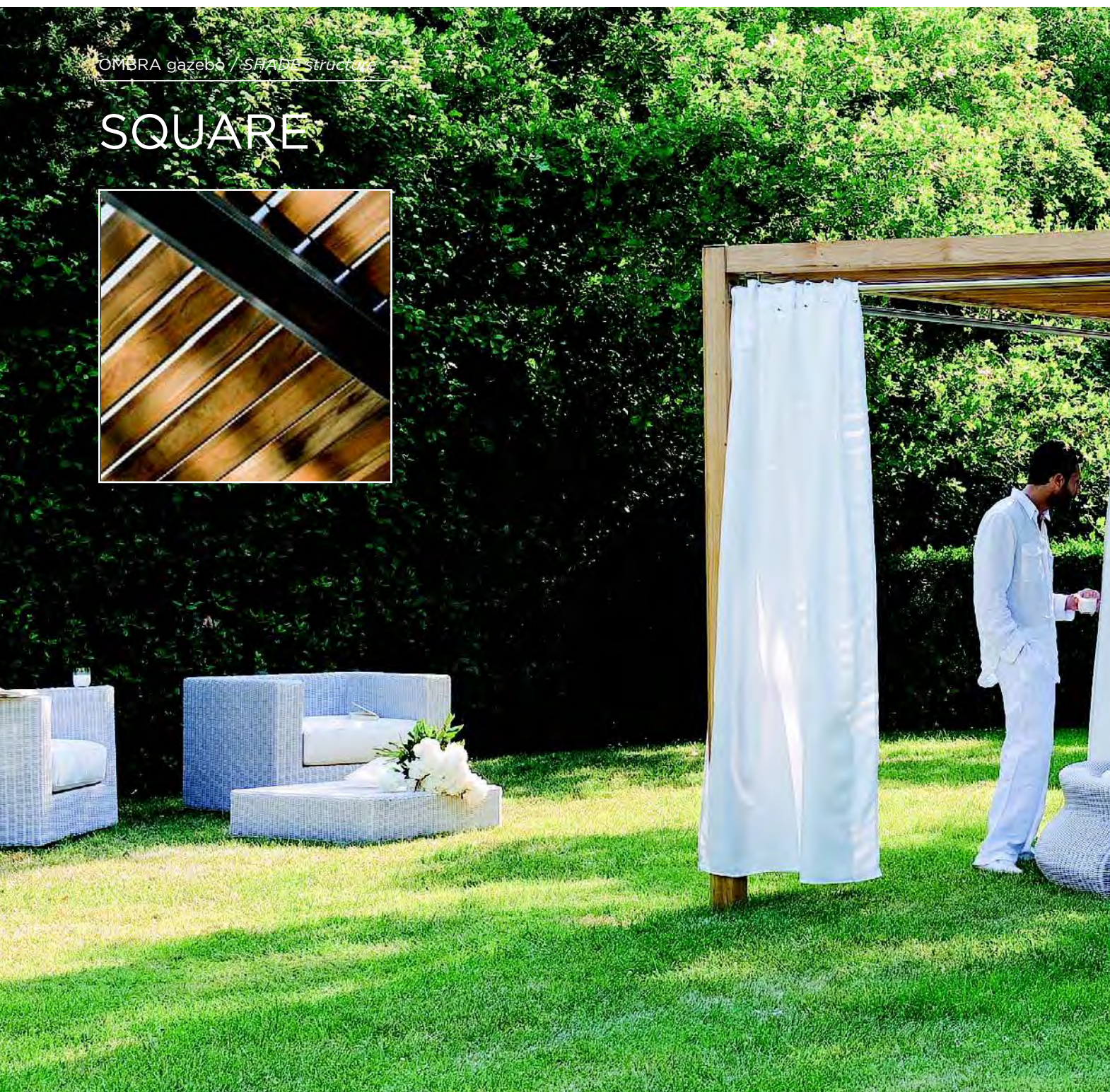



FLAIR



FIORIERE legno / PLANTERS wood

MATI

Designed by
Francesca Marzotto Caotorta



LUCE lampade teak e alluminio / *LIGHTING teak and aluminium lights*

GINGER

Designed by
Niccolò Grassi





LUCE lampade terracotta senese /
LIGHTING Siena terracotta

STEP

Designed by
Niccolò Grassi



LUCE lampade terracotta senese /
LIGHTING Siena terracotta

TOUR

Designed by
Niccolò Grassi



COMPLEMENTI / COMPLEMENTS

CUSHIONS





MATERIALI

QUALITÀ E INNOVAZIONE

GLI ELEMENTI DI ARREDO DA GIARDINO ETHIMO SI DISTINGUONO PER L'ACCURATA SELEZIONE DEI MATERIALI, PER LE TECNICHE DI LAVORAZIONE E DI FINITURA ALL'AVANGUARDIA E PER LA RICERCA DI SOLUZIONI SEMPRE NUOVE E FUNZIONALI.

ETHIMO AFFIANCA ALLA RICERCA E ALL'INNOVAZIONE TECNOLOGICA UNA PARTICOLARE ATTENZIONE PER LE FINITURE REALIZZATE CON SISTEMI ARTIGIANALI CHE ASSICURANO LA MASSIMA CURA DEL DETTAGLIO.

IL RISULTATO È UN PRODOTTO DI DESIGN, FUNZIONALE, DUREVOLE E DI ELEVATA QUALITÀ.

MATERIALS

QUALITY AND INNOVATION

ETHIMO OUTDOOR FURNISHING IS SET APART FOR THE HIGH QUALITY OF ITS MATERIALS, STATE-OF-THE-ART PRODUCTION PROCESS AND THE CONSTANT PURSUIT OF INNOVATION.

ETHIMO BACKS THIS UP BY DEVISING NEW, PRACTICAL DESIGN SOLUTIONS AND SPECIAL ATTENTION TO THE FINISHES, MADE WITH HANDCRAFT SYSTEM THAT ENSURE OPTIMAL ATTENTION TO DETAIL.

THE RESULT IS A LONG-LASTING, STRONG, RELIABLE PRODUCT, CHARACTERIZED BY ITALIAN STYLE AND DESIGN.

LIGHTWICK

LA FIBRA LIGHTWICK DI ETHIMO È UN INTRECCIO FORMATO DA UN FILO BASE DI DIAMETRO 2 MM A SEZIONE ROTONDA CON CUI SONO REALIZZATE MAGLIE DIVERSE CHE DANNO VITA AD UNA TRAMA IRREGOLARE MOLTO CONFORTEVOLE. COMBINATA CON LA STRUTTURA DI ALLUMINIO, È IDEALE PER REALIZZARE ELEMENTI DALL'ESTREMA LEGGEREZZA E RESISTENZA.

ETHIMO LIGHTWICK FIBRE IS A WEAVING COMPOSED OF A WIRE BASE WITH A DIAMETER OF 2 MM WITH A ROUND SECTION USED TO CREATE DIFFERENT MESHES CARRYING OUT AN IRREGULAR, VERY COMFORTABLE PATTERN. COMBINED WITH THE ALUMINIUM FRAME, IT GIVES SHAPE TO OUTDOOR ELEMENTS CHARACTERIZED BY EXTREME LIGHTNESS AND STRENGTH.



WARMGREY



WARMWHITE

ETWICK

LA FIBRA ETWICK DI ETHIMO È UN MATERIALE SINTETICO RICICLABILE CHE RIPRODUCE L'ASPETTO DEL MIDOLLINO ASSOLUTAMENTE INATTACCABILE DA AGENTI ATMOSFERICI E DAL TRASCORRERE DEL TEMPO. È INTRECCIATA A MANO ED HA UNA FINITURA RUVIDA CHE LA RENDE PERFETTAMENTE NATURALE AL TATTO E ALLA VISTA.

ETHIMO ETWICK FIBER IS COMPLETELY RECYCLABLE AND RECREATES WICKER'S NATURAL LOOK. IT PERFECTLY WITHSTANDS THE ELEMENTS AND THE PASSAGE OF TIME. IT IS HANDWOVEN AND IT HAS A ROUGH FINISH WHICH MAKES IT PERFECTLY NATURAL TO THE TOUCH AND SIGHT.



BARK



WHITE

TEAK

IL TEAK SELEZIONATO DA ETHIMO PROVIENE DALLE PIANTAGIONI REGOLAMENTATE DI THAILANDIA E INDONESIA. È UN MATERIALE ECCELLENTE, DI ELEVATA QUALITÀ, IDEALE PER LA REALIZZAZIONE DI MOBILI DA ESTERNO PERCHÉ ESTREMAMENTE RESISTENTE AI CAMBIAMENTI DI TEMPERATURA, ALL'ACQUA, ALL'UMIDITÀ E ALLA SALSEDINE.

ETHIMO TEAK COMES FROM CONTROLLED FOREST PLANTATIONS IN THAILAND AND INDONESIA. THE RESULT IS AN EXCELLENT, HIGH QUALITY MATERIAL, IDEAL FOR OUTDOOR FURNITURE. IT IS PARTICULARLY RESISTANT TO CHANGES IN TEMPERATURE, WATER, HUMIDITY AND SALTWATER.



TEAK

TEAK DECAPATO

PER DONARE AL TEAK DELLA MIGLIORE QUALITÀ UN FASCINO VINTAGE ED UNO STILE SHABBY CHIC, QUESTO VIENE TRATTATO CON LA FINITURA DECAPATA. INNANZITUTTO VIENE SPAZZOLATO RENDENDO LA SUPERFICIE PIÙ RUVIDA E INVECCHIATA, PRIVANDOLA DELLA NATURALE PATINA OLEOSA. POI VIENE PROTETTO CON UN TRATTAMENTO CHE LO FA APPARIRE GRIGIO SIN DALL'INIZIO. COL TEMPO ACQUISIRÀ LA NATURALE PATINA GRIGIA ARGENTEA DEL TEAK NON TRATTATO, MANTENENDO AL TATTO LA FINITURA SPAZZOLATA. QUESTO TIPO DI TEAK NON DEVE ESSERE TRATTATO CON OLIO, MA SOLTANTO PULITO CON ACQUA E SAPONE.

PICKLED TEAK

TO GIVE THE BEST QUALITY TEAK A VINTAGE AND SHABBY CHIC CHARM, THIS IS TREATED WITH PICKLED FINISH. FIRST IT IS BRUSHED, MAKING THE SURFACE ROUGHER AND OLDER, DEPRIVING IT OF THE NATURAL OILY FILM. THEN IT IS PROTECTED WITH A TREATMENT THAT MAKES IT LOOK GRAY FROM THE START. OVER TIME, IT TAKES ON THE NATURAL SILVER GRAY PATINA, LIKE UNTREATED TEAK, KEEPING THE BRUSHED FINISH TO THE TOUCH. THIS TYPE OF TEAK SHOULD NOT BE TREATED WITH OIL, BUT ONLY CLEANED WITH SOAP AND WATER.



PICKLED TEAK

MOGANO VERNICIATO

PER GLI ELEMENTI DI ARREDO IN LEGNO VERNICIATO ETHIMO HA SCELTO IL MOGANO PROVENIENTE DA PIANTAGIONI INDONESIAE REGOLAMENTATE. IL MOGANO È UN LEGNO MOLTO RESISTENTE E ADATTO ALL'USO ALL'ESTERNO, UTILIZZATO COMUNEMENTE ANCHE PER LA COSTRUZIONE DELLE IMBARCAZIONI. DOPO L'ESSICCAZIONE E PRIMA DELLA VERNICIATURA, IL LEGNO VIENE TRATTATO CON UN PRODOTTO SIGILLANTE CHE CHIUDE I PORI RENDENDOLO IMPERMEABILE. LE VERNICI UTILIZZATE SONO RESISTENTI AGLI AGENTI ATMOSFERICI E ALLE INTEMPERIE, GARANTITE DA UNA SPECIALE PROCEDURA PER IL FISSAGGIO DEL COLORE.

PAINTED MAHOGANY

AS FOR PAINTED WOODEN FURNITURE, ETHIMO CHOOSES MAHOGANY WOOD COMING FROM REGULATED INDONESIAE PLANTATIONS. MAHOGANY IS A VERY DURABLE HARDWOOD, EXTREMELY SUITABLE FOR OUTDOOR USE, ALSO COMMONLY USED IN BOAT BUILDING. AFTER DRYING AND BEFORE PAINTING, THE WOOD IS TREATED WITH A SEALANT WHICH CLOSES THE PORES MAKING IT WATERPROOF. THE PAINTS USED ARE WEATHER RESISTANT AND WEATHERPROOF, GUARANTEED BY A SPECIAL PROCEDURE FOR FIXING THE COLOUR.



PANTELLERIA BLUE



OSTUNI WHITE



LANGHE GREEN



LIPARI GREY



AGAVE GREEN

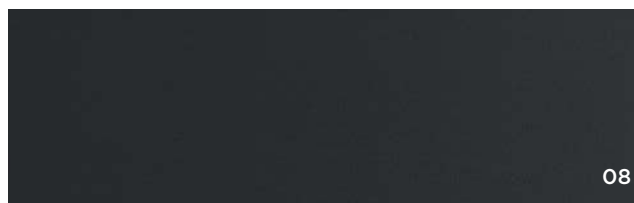

STROMBOLI BLACK



CORAL RED

TERRACOTTA

L'ARGILLA CON CUI SONO REALIZZATE LE LAMPADE DA GIARDINO STEP E TOUR SI TROVA NATURALMENTE IN UN PARTICOLARE ECOSISTEMA NEL TERRITORIO DELLE PROVINCE DI SIENA, AREZZO E GROSSETO, IN UNA DELLE PIÙ BELLE AREE DELLA TOSCANA.

L'ARGILLA PRENDE VITA TRA LE MANI DI ESPERTI LAVORATORI DELLE FORNACI DELLA VAL DI CHIANA, IN PROVINCIA DI SIENA, ADATTANDOSI ALLA FORMA DELLO STAMPO. TOLTO DALLO STAMPO, IL PEZZO VIENE PURIFICATO DALLE IMPERFEZIONI. E' IN QUESTA FASE CHE, GRAZIE ALLA MANUALITÀ DEGLI OPERATORI, AVVIENE LA DEFINITIVA ESALTAZIONE DELL'ESTETICA DEL MANUFATTO.

DOPO UNA LENTA ED OMOGENEA FASE DI DISIDRATAZIONE, I PRODOTTI VENGONO DISPOSTI NEI FORNI PER LA COTTURA, CHE NECESSITA DI CIRCA 3 GIORNI, RAGGIUNGENDO UNA TEMPERATURA MASSIMA DI CIRCA 1000 GRADI.

THE CLAY WHICH THE GARDEN LAMPS STEP AND TOUR ARE MADE OF, OCCURS NATURALLY IN A PARTICULAR ECOSYSTEM IN THE PROVINCES OF SIENA, AREZZO AND GROSSETO, IN ONE OF THE MOST BEAUTIFUL AREAS OF TUSCANY.

THE CLAY COMES TO LIFE IN THE HANDS OF EXPERIENCED WORKERS IN THE FURNACES OF THE VAL DI CHIANA, ADAPTING TO THE SHAPE OF THE MOLD. REMOVED FROM THE MOLD, THE WORKPIECE IS PURIFIED BY IMPERFECTIONS. THEN, THANKS TO THE DEXTERITY OF THE OPERATORS, IT TAKES PLACE THE FINAL AESTHETIC EXALTATION OF THE ITEM.

AFTER A SLOW AND HOMOGENEOUS PHASE OF DEHYDRATION, THE PRODUCTS ARE PLACED IN OVENS FOR COOKING, WHICH REQUIRES ABOUT 3 DAYS, REACHING A MAXIMUM TEMPERATURE OF ABOUT 1000 DEGREES.



WHITE

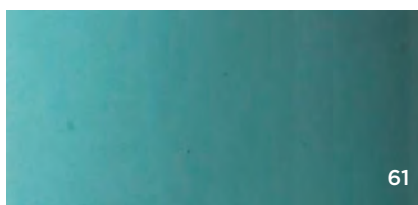

TURQUOISE BLUE

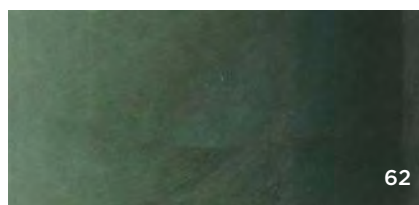

GREEN



LEAD GREY METAL



TERRACOTTA



RED EARTH



MUD GREY



MOSS GREEN

METALLO

IL METALLO ETHIMO È LAVORATO E TRATTATO CON PROCESSI CHE NE GARANTISCONO LA QUALITÀ, LA RESISTENZA E LA DURABILITÀ ALL'ESTERNO. TUTTA LA FERRAMENTA UTILIZZATA È IN ACCIAIO INOSSIDABILE E LA VERNICIATURA È EFFETTUATA CON VERNICI A POLVERI EPOSSIDICHE SPECIFICHE PER L'USO ALL'ESTERNO.

METAL

ETHIMO METAL IS PROCESSED AND TREATED TO ENSURE OPTIMAL QUALITY, RUST RESISTANCE, STRENGTH AND DURABILITY WHEN USED OUTDOORS. ALL THE HARDWARE USED IS STAINLESS STEEL AND THE PAINT IS MADE WITH EPOXY POWDER PAINTS SPECIFIC FOR OUTDOOR USE.



GLOSSY 3000

PEONY
FUCHSIA

MATT 3100
LILY OF THE
VALLEY WHITE



MATT 3200

SAGE
GREEN

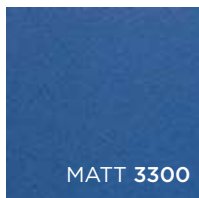

MATT 3300

CORN FLOWER
BLUE

PERIWINKLE
LILAC

OLIVE
GREEN

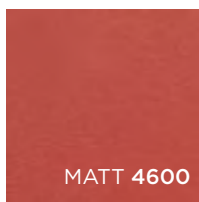

MATT 4600

BAMBOO
GREEN

MUD
GREY

PLUMBAGO
BLUE

CORAL
RED

POPPY
RED

SEPIA
BLACK



MATT 4900

LEAD
GREY



MATT 5100

COFFEE
BROWN

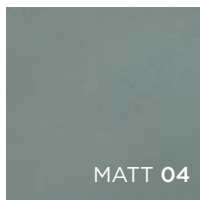

MATT 04

LANGHE
GREEN

LIPARI
GREY



MATT 37

AMBER
GREY

MATT 4300

WARMWHITE
ALUMINIUM

WARMGREY
ALUMINIUM



52

ALUMINIUM



MATT 54

ALUMINIUM

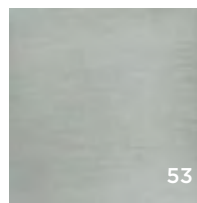

53

STAINLESS
STEEL

TESSUTI

TUTTI I TESSUTI UTILIZZATI DA ETHIMO PER I PROPRI ARREDI SONO IDROREPELLENTI CON TRATTAMENTO IMPERMEABILIZZANTE E RESISTENTI AI RAGGI UV.

FABRICS

ALL FABRICS USED BY ETHIMO FOR ITS FURNISHING ARE WATERPROOF AND UV-RESISTANT.

ACRYLIC

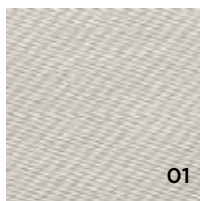

IVORY

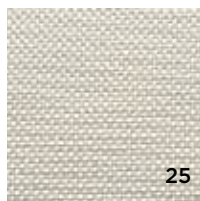

NATURE
WHITE

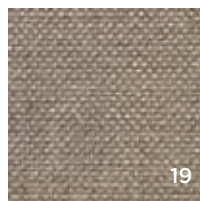

GREY
SUN

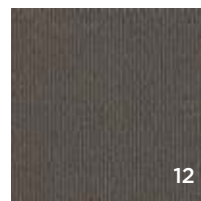

DOVE
GREY

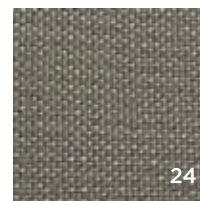

NATURE
GREY

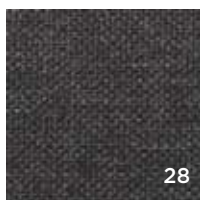

BLACK
STONE

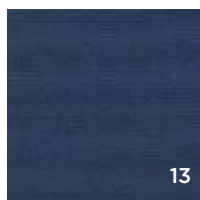

NIGHT
BLUE

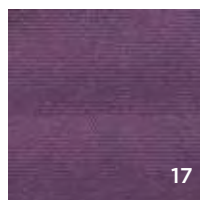

PLUM

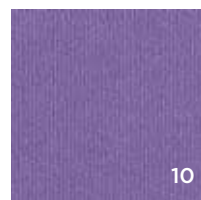

WISTERIA
LILAC

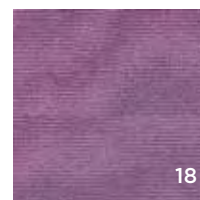

LILAC
SUN



OLIVE
GREEN

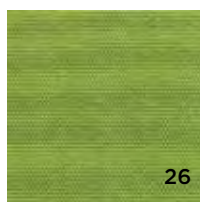

LIME



STRIPED

ACRYLIC
FANTASY



BEIGE
BACKGROUND



WHITE
BACKGROUND



GREY
BACKGROUND

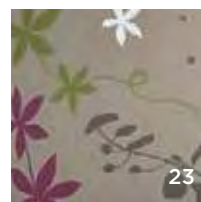

DOVE
BACKGROUND

COTTON

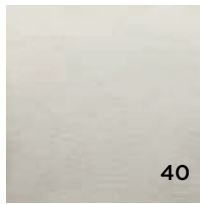

40

IVORY

TEXPLAST

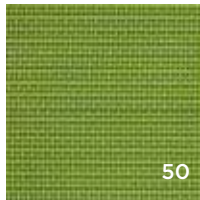

50

APPLE GREEN



51

LILAC

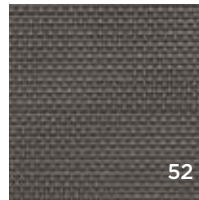

52

DOVE GREY

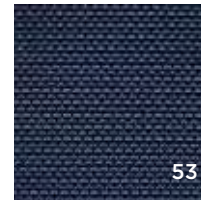

53

BLUE



54

STRIPED

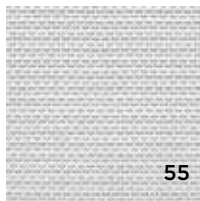

55

WHITE

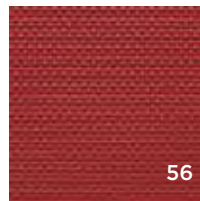

56

RED

POLYESTER



07

WHITE

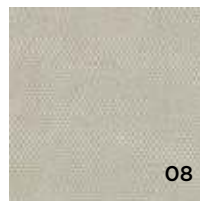

08

IVORY

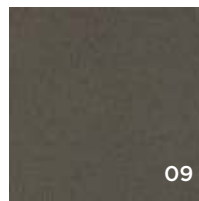

09

DOVE

VELUM

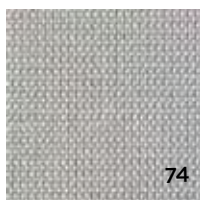

74

WHITE

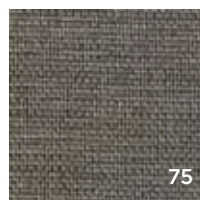

75

GREY

COLLECTIONS

COME LEGGERE LE INFORMAZIONI TECNICHE

PER OGNI COLLEZIONE SONO INDICATI I MATERIALI E/O I COLORI IN CUI È DISPONIBILE E GLI EVENTUALI TESSUTI DI COMPLETAMENTO.

IL CODICE ACCOMPAGNATO DAL QUADRATINO COLORATO FA RIFERIMENTO ALL'ARTICOLO NELLA SPECIFICA VARIANTE DI COLORE/MATERIALE. NEI CASI IN CUI IL CODICE NON È ACCOMPAGNATO DAL QUADRATINO COLORATO È GENERICO E IL PRODOTTO DEVE ESSERE COMPLETATO CON L'INDICAZIONE DEL COLORE DEL MATERIALE E/O DEL TESSUTO.

PER OGNI ELEMENTO SONO RIPORTATE DIMENSIONI, PESO, CARATTERISTICHE E RELATIVO IMBALLO.

LE CARATTERISTICHE SONO INDICATE DAI SIMBOLI RIPORTATI QUI ACCANTO.

HOW TO READ THE TECHNICAL INFORMATION

FOR EACH COLLECTION ARE INDICATED THE MATERIALS AND / OR COLOURS AVAILABLE AND ANY COMPLEMENTARY FABRICS.

THE CODE WITH THE COLOURED CHIP REFERS TO THE ARTICLE IN THE SPECIFIC VARIATION OF COLOUR / MATERIAL. WHEN THE CODE IS NOT ACCOMPANIED BY COLOURED CHIP, IT IS GENERIC AND IT MEANS THAT THE PRODUCT MUST BE COMPLETED WITH INDICATION OF COLOUR MATERIAL AND / OR FABRIC.

FOR EACH ELEMENT ARE LISTED SIZE, WEIGHT, FEATURES AND ITS PACKAGING.

ALL SPECIFICATIONS ARE INDICATED BY SYMBOLS HERE NEXT.

LEGENDA/ LEGEND

	Peso in Kg / <i>Weight - Kilogram</i>
	Modulare / <i>Modular</i>
	Posti tavola / <i>Number of seats</i>
	Impilabile / <i>Stackable</i>
	Da assemblare / <i>To assemble</i>
	Pieghevole / <i>Foldable</i>
	Tavolo allungabile / <i>Extendable table</i>
	Dotato di foro per ombrellone / <i>Equipped with a hole for umbrella</i>
	Lettino con schienale regolabile / <i>Sunbed with adjustable backrest</i>
	Posizione regolabile / <i>Adjustable position</i>
	Pezzi contenuti nell'imballo / <i>Pieces in packaging</i>
	Volume dell'imballo / <i>Volume</i>
	Cuscini complementari / <i>Complementary cushions</i>
	Impermeabile / <i>Waterproof</i>
	Resistente ai raggi UV / <i>UV resistant</i>
	Colore non disponibile / <i>non available colour</i>

COSTES PAG. 6

IL SALOTTO COSTES È PROPOSTO IN TEAK CON FINITURA DECAPATA O IN MOGANO VERNICIATO.

COSTES SOFA IS AVAILABLE IN PICKLED TEAK OR IN PAINTED MAHOGANY.

MATERIALE / MATERIAL

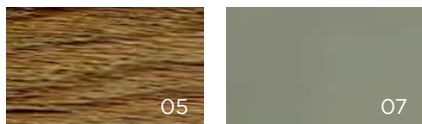

CUSCINI / CUSHIONS

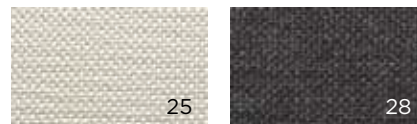

PRODUCT	DRAWING	INFO	PACK	ART.
3 seater sofa	180x80 h70 cm 	40 	1 185X83 h72 cm 46	CODI05 CODI07
Seat and back cushion				
Nature White				CODICU25
Black Stone				CODICU28
Armchair	80x80 h70 cm 	24 	1 85X83 h72 cm 28	COPO05 COPO07
Seat and back cushion				
Nature White				COPOCU25
Black Stone				COPOCU28
Coffee table	100x60 h38 cm 	16 	1 105X65 h10 cm 20	COTR05 COTR07

INFINITY PAG. 12

UN'AMPIA COLLEZIONE IN ALLUMINIO E FIBRA LIGHTWICK IN DUE TONALITÀ, COMPOSTA DA UN SISTEMA MODULARE DI SEDUTE LOUNGE, TAVOLINI E PUFF, TAVOLI E SEDIE, LETTINI PRENDISOLE.





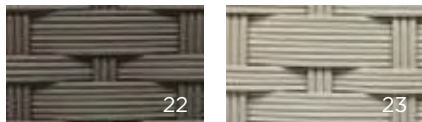



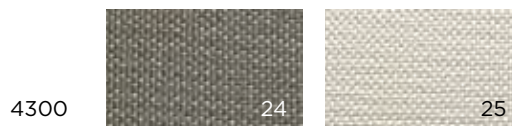

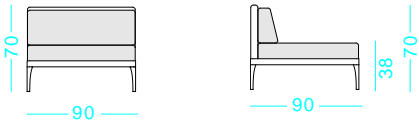









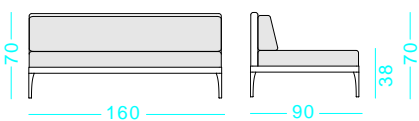

A LARGE COLLECTION OF TWO-TONED ALUMINIUM AND LIGHTWICK FIBER, COMPOSED OF A MODULAR LOUNGE SOFA, COFFEE TABLES AND POUF, TABLES AND CHAIRS, SUN LOUNGER.











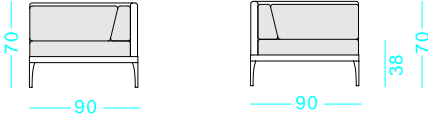











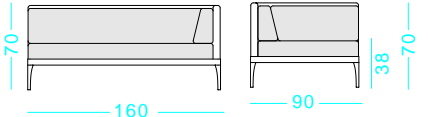











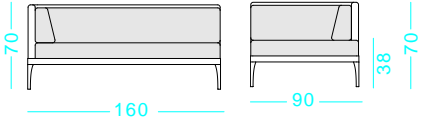









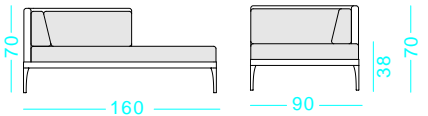

MATERIALE / MATERIAL











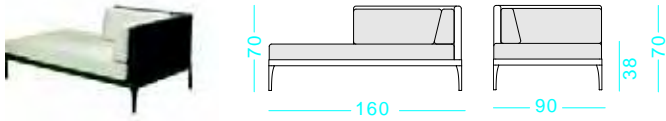









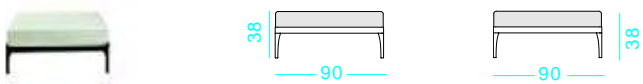









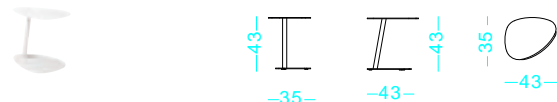





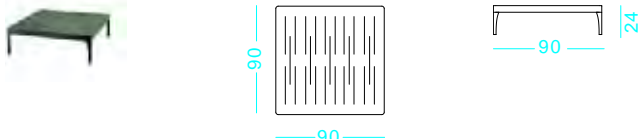







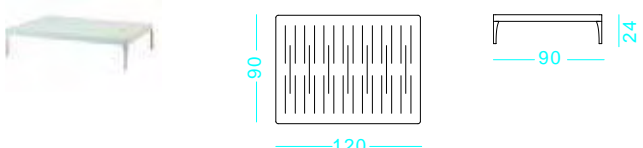









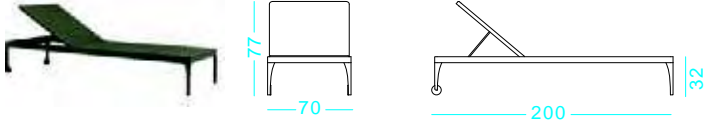









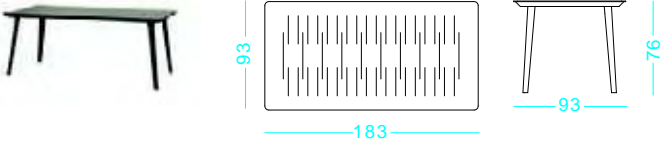







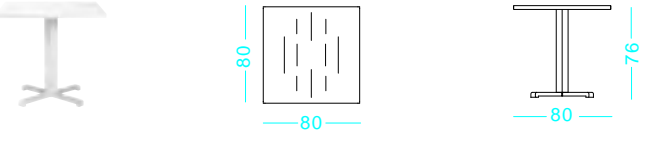







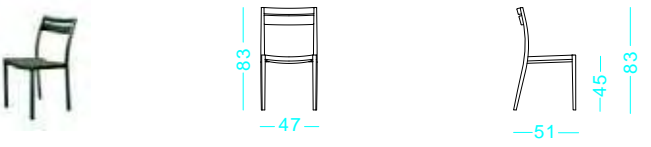





CUSCINI / CUSHIONS

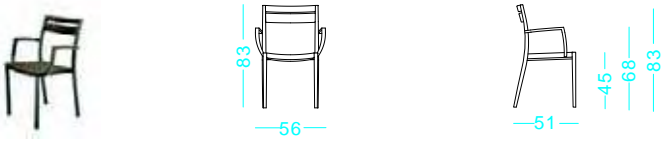

PRODUCT	DRAWING	INFO	PACK	ART.
<p>Central module</p> 	<p>90x90 h70 cm</p> 	  13 	 1  95X95 h75 cm  16	<p> IFCP2200</p> <p> IFCP2300</p>
Seat and back cushion				
Nature White				 IFCPCU25
Nature Grey				 IFCPCU24
<p>XL central module</p> 	<p>160x90 h70 cm</p> 	  21 	 1  165X95 h75 cm  25	<p> IFCG2200</p> <p> IFCG2300</p>
Seat and back cushion				
Nature White				 IFCGCU25
Nature Grey				 IFCGCU24

PRODUCT	DRAWING	INFO	PACK	ART.
Corner module 	90x90 h70 cm 	  15 	 1  95X95 h75 cm  18	 IFAN2200  IFAN2300
Seat and back cushion				
Nature White				 IFANCU25
Nature Grey				 IFANCU24
XL right corner module 	160x90 h70 cm 	  23 	 1  165X95 h75 cm  27	 IFFD2200  IFFD2300
Seat and back cushion				
Nature White				 IFFDCU25
Nature Grey				 IFFDCU24
XL left corner module 	160x90 h70 cm 	  23 	 1  165X95 h75 cm  27	 IFFS2200  IFFS2300
Seat and back cushion				
Nature White				 IFFSCU25
Nature Grey				 IFFSCU24
Left daybed module 	160x90 h70 cm 	  21 	 1  165X95 h75 cm  25	 IFLS2200  IFLS2300
Seat and back cushion				
Nature White				 IFLSCU25
Nature Grey				 IFLSCU24

PRODUCT	DRAWING	INFO	PACK	ART.
Right daybed module	160x90 h70 cm 	  21 	 1  165X95 h75 cm  25	 IFLD2200  IFLS2300
Seat and back cushion				
Nature White				 IFLDCU25
Nature Grey				 IFLDCU24
Pouf	90x90 h38 cm 	  11	 1  95X95 h40 cm  14	 IFPU2200  IFPU2300
Seat cushion				
Nature White				 IFPUCU25
Nature Grey				 IFPUCU24
Side table	43x35 h43 cm 	 2	 1  48X45 h45 cm  3	 IFST4400  IFST4300
Square coffee table	90x90 h24 cm 	  11	 1  95X95 h30 cm  13	 IFTB4400  IFTB4300
Rectangular coffee table	120x90 h24 cm 	  16	 1  125X95 h30 cm  18	 IFTR4400  IFTR4300

PRODUCT	DRAWING	INFO	PACK	ART.
Sun lounger	200x70 h32 cm 	  15	 1  210X73 h50 cm  20	 IFLE2200  IFLE2300
Mattress				
Nature White				 IFLEMS25
Nature Grey				 IFLEMS24
Rectangular table	183x93 h76 cm 	 8  45  50	 1  190X100 h25 cm  50	 IFTA2200  IFTA2300
Square table	80x80 h76 cm 	 4  25  30	 1  85X85 h18 cm  30	 IFTP4400  IFTP4300
Chair	47x51 h83 cm 	 3  16	 4  67X55 h104 cm  16	 IFSE2200  IFSE2300
Armchair	56x51 h83 cm 	 4  20	 4  70X63 h104 cm  20	 IFSB2200  IFSB2300

TAPISSERIE PAG. 20











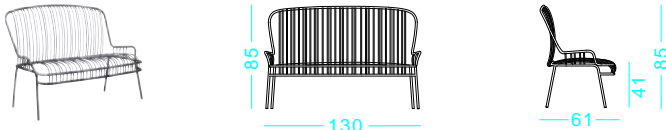





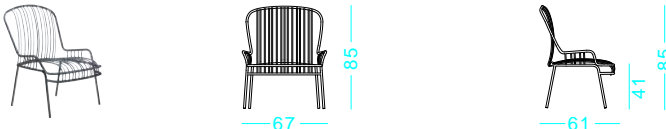

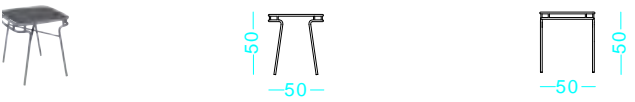

LA COLLEZIONE RIPRODUCE L'EFFETTO DEL TESSUTO RIGATO ATTRAVERSO L'UTILIZZO DEL TONDINO CURVATO AD ARTE CHE REALIZZA L'ILLUSIONE DI UN'IMBOTTITURA. L'EFFETTO TRIDIMENSIONALE È AMPLIFICATO DALL'USO DEL COLORE.

METAL COLLECTION REPRODUCING THE EFFECT OF STRIPED FABRIC THROUGH THE USE OF IRON ROD SKILLFULLY BENT TO ACHIEVE THE ILLUSION OF A PADDING. THE THREE-DIMENSIONAL EFFECT IS AMPLIFIED BY THE USE OF COLOUR.

MATERIALE / MATERIAL

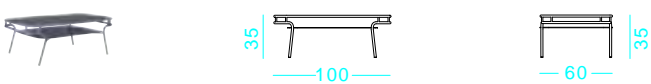
CUSCINI / CUSHIONS



PRODUCT	DRAWING	INFO	PACK	ART.
2 seater sofa	130x61 h85 cm 	 27	 1 135X74 h92 cm  32	 TPDI4441
Seat and back cushion				
Nature grey				 TPDICU24
Armchair	67x61 h85 cm 	 11	 1 73X73 h92 cm  15	 TPPO4441
Seat and back cushion				
Nature grey				 TPPOCU24
Square coffee table	50x50 h50 cm 	 8	 1 60X60 h63 cm  11	 TPTQ4441
Rectangular coffee table	100x60 h35 cm 	 18	 1 106X64 h40 cm  22	 TPTR4441

SUMMER PAG. 22

LA COLLEZIONE SUMMER IN METALLO COLORATO È COMPOSTA DA SEDIA E POLTRONCINA IMPILABILI, TAVOLO E PANCHE.

COLOURED METAL SUMMER COLLECTION COMPOSED OF STACKABLE CHAIR AND ARMCHAIR, TABLE AND BENCHES.

MATERIALE / MATERIAL

4300

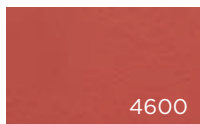

4600

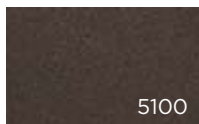









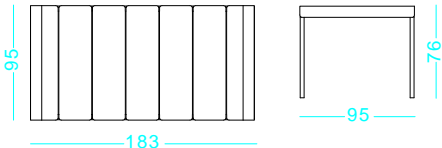

































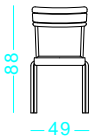
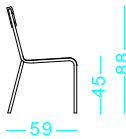









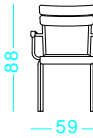
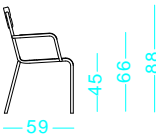







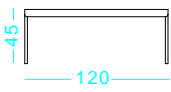

5100

TESSUTI / FABRICS



01

PRODUCT	DRAWING	INFO	PACK	ART.
<p>Rectangular table</p> 	<p>183x95 h76 cm</p> 	<p>  6-8  40  </p>	<p>  1  195X104 h25 cm  48 </p>	<p>  SUTR4300  SUTR4000  SUTR4600  SUTR5100 </p>
<p>Square table</p> 	<p>100x95 h76 cm</p> 	<p>  4  25  </p>	<p>  1  100X100 h22 cm  29 </p>	<p>  SUTQ4300  SUTQ4000  SUTQ4600  SUTQ5100 </p>

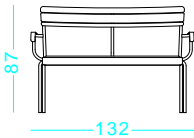
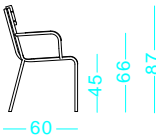
PRODUCT	DRAWING	INFO	PACK	ART.
Stackable chair	49x59 h88 cm	 	  	 SUSE4300  SUSE4000  SUSE4600  SUSE5100
	  			
Stackable armchair	59x59 h88 cm	 	  	 SUSB4300  SUSB4000  SUSB4600  SUSB5100
	  			
Seat cushion				
Ivory				 SUSECU01
Bench	120x45 h45 cm	 	  	 SUPA4300  SUPA4000  SUPA4600
	  			
Bench with arms	132x60 h87 cm	 	  	 SUPB4300  SUPB4000  SUPB4600
	  			









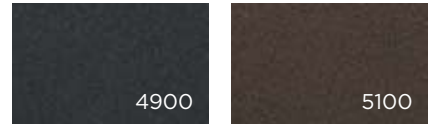
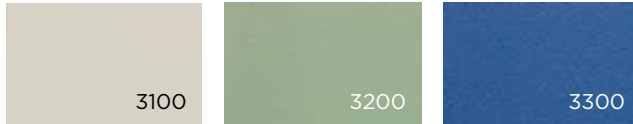

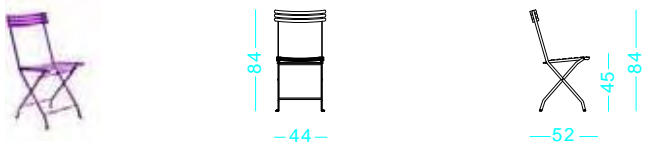



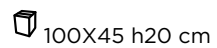

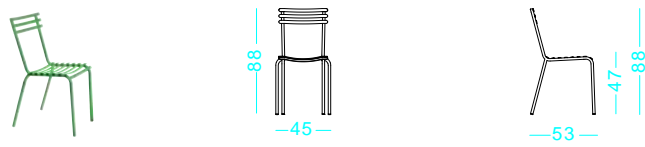

FLOWER PAG. 26

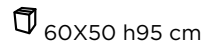
AMPIA COLLEZIONE IN METALLO COLORATO
 PROPOSTA IN 12 COLORI, COMPOSTA DA TAVOLI
 DI VARIE FORME E DIMENSIONI, SEDUTE E
 LETTINO PRENDISOLE.

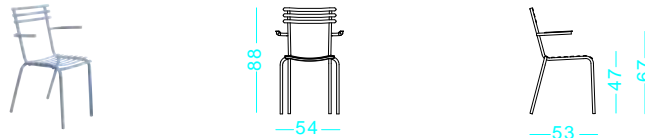
A LARGE AND COLOURED METAL COLLECTION,
 COMPOSED OF TABLES, CHAIRS AND SUNBED.

MATERIALE / MATERIAL

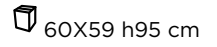









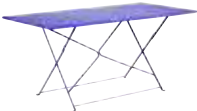
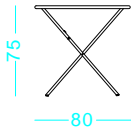
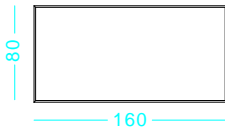







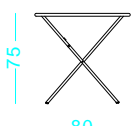
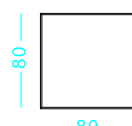







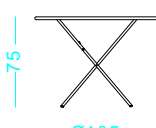
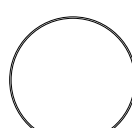







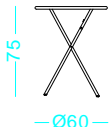
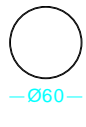







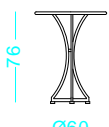
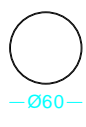





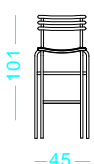
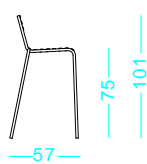



















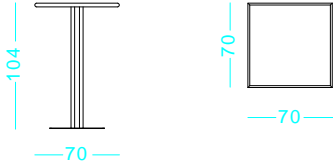









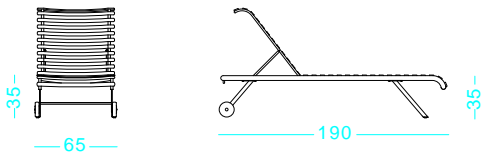



PRODUCT	DRAWING	INFO	PACK	ART.
Folding chair	44x52 h84 cm 	↔  	 2  100X45 h20 cm  14	FLSE
Stackable chair	45x53 h88 cm 	 	 4  60X50 h95 cm  28	FLSI
Stackable armchair	54x53 h88 cm 	 	 4  60X59 h95 cm  32	FLSB

Chair cushion

Ivory

 **FLSECU01**

PRODUCT	DRAWING	INFO	PACK	ART.
Rectangular folding table 160x80 h75 cm	  	 6   23	 1  165X115 h10 cm  29	FLTR  FLTR39
Square folding table 80x80 h75 cm	  	 4   10	 1  106X83 h10 cm  17	FLTQ  FLTQ39
Round folding table diam. 105 h75 cm	  	 5   16	 1  120X108 h10 cm  20	FLTT  FLTT39
Round folding table diam. 60 h75 cm	  	 2   6	 1  100X65 h10 cm  10	FLTO  FLTO39
Round table diam.60 h76 cm	  	 2  10	 1  68X68 h70 cm  11	<input type="checkbox"/> FLTF3100 <input checked="" type="checkbox"/> FLTF4000 <input checked="" type="checkbox"/> FLTF4900 <input checked="" type="checkbox"/> FLTF5100
High stool 45x57 h101 cm	  	 7  16	 2  70X50 h135 cm  16	<input type="checkbox"/> FLSA3100 <input checked="" type="checkbox"/> FLSA3900 <input checked="" type="checkbox"/> FLSA4000 <input checked="" type="checkbox"/> FLSA5100

PRODUCT	DRAWING	INFO	PACK	ART.
Square table 	70x70 h75 cm 	 4   34	 1 table top  75X75 h8 cm  30  1 table top  9X9 h72 cm  4	<input type="checkbox"/> FLTP3100 <input checked="" type="checkbox"/> FLTP4000 <input checked="" type="checkbox"/> FLTP4900 <input checked="" type="checkbox"/> FLTP5100
High table 	70x70 h104 cm 	 2-4   35	 1 table top  75X75 h8 cm  30  1 table top  9X9 h106 cm  5	<input type="checkbox"/> FLTA3100 <input checked="" type="checkbox"/> FLTA4000 <input checked="" type="checkbox"/> FLTA4900 <input checked="" type="checkbox"/> FLTA5100
Sunbed with adjustable backrest 190x65 h35 cm 		   37	 1  215X72 h15 cm  40	<input type="checkbox"/> FLLE3100 <input checked="" type="checkbox"/> FLLE3300 <input checked="" type="checkbox"/> FLLE4100 <input checked="" type="checkbox"/> FLLE5100
Mattress Ivory				<input checked="" type="checkbox"/> FLCL0001
Coffee table 	diam. 60 h50-56 cm 	  6	 1  103X67 h10 cm  9	<input type="checkbox"/> FLTB3100 <input checked="" type="checkbox"/> FLTB4000 <input checked="" type="checkbox"/> FLTB3300 <input checked="" type="checkbox"/> FLTB4100 <input checked="" type="checkbox"/> FLTB5100

ELISIR PAG. 36

COLLEZIONE IN METALLO IN QUATTRO COLORI
 COMPOSTA DA TAVOLO QUADRATO E
 RETTANGOLARE ALLUNGABILE CON PROLUNGA
 A SCOMPARSA, SEDIA E POLTRONCINA,
 LETTINO PRENDISOLE.









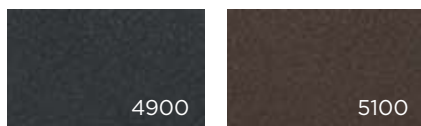

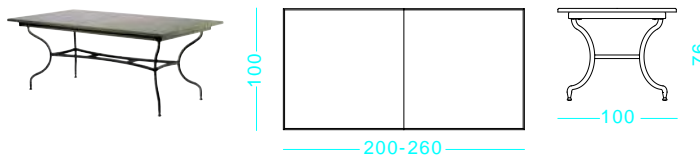



METAL COLLECTION IN FOUR COLORS WITH
 SQUARE AND RECTANGULAR EXTENDING TABLE,
 CHAIR AND ARMCHAIR, SUNBED.



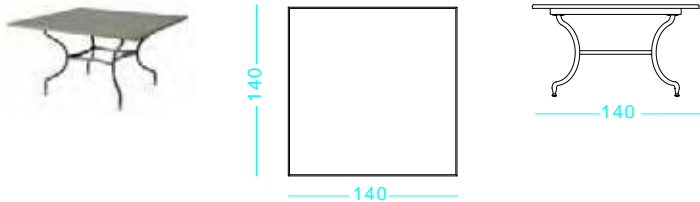







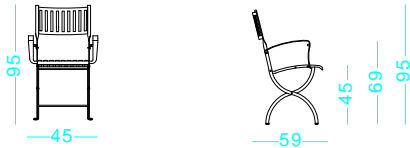











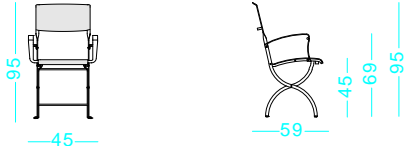





MATERIALE / MATERIAL

COLORE TEXPLAST / TEXPLAST COLOUR

3100

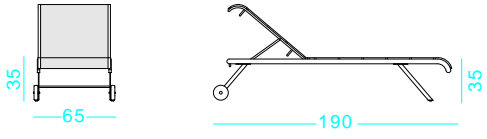

PRODUCT	DRAWING	INFO	PACK	ART.
Rectangular table	200-260x100 h76 cm 	 8-10  85  	 1  220X120 h38 cm  121	<input type="checkbox"/> EITR3100 <input checked="" type="checkbox"/> EITR4000 <input checked="" type="checkbox"/> EITR4900 <input checked="" type="checkbox"/> EITR5100
Square table	140x140 h76 cm 	 8  65 	 1  145X145 h23 cm  90	<input type="checkbox"/> EITQ3100 <input checked="" type="checkbox"/> EITQ4000 <input checked="" type="checkbox"/> EITQ4900 <input checked="" type="checkbox"/> EITQ5100

PRODUCT	DRAWING	INFO	PACK	ART.
<p>Armchair</p> 	<p>45x59 h95 cm</p> 	<p>↔</p> <p> 11</p>	<p> 2</p> <p> 110X43 h62 cm</p> <p> 25</p>	<p><input type="checkbox"/> EISB3100</p> <p><input checked="" type="checkbox"/> EISB4000</p> <p><input checked="" type="checkbox"/> EISB4900</p> <p><input checked="" type="checkbox"/> EISB5100</p>
<p>Chair</p> 	<p>45x59 h95 cm</p> 	<p>↔</p> <p> 8</p>	<p> 2</p> <p> 110X43 h62 cm</p> <p> 20</p>	<p><input type="checkbox"/> EISE3100</p> <p><input checked="" type="checkbox"/> EISE4000</p> <p><input checked="" type="checkbox"/> EISE4900</p> <p><input checked="" type="checkbox"/> EISE5100</p>
<p>Chair cushion</p>				<p><input checked="" type="checkbox"/> EISECU01</p>
<p>Metal and Texplast armchair 45x59 h95 cm</p> 	<p>45x59 h95 cm</p> 	<p>↔</p> <p> 7</p>	<p> 2</p> <p> 110X43 h62 cm</p> <p> 22</p>	<p><input type="checkbox"/> <input type="checkbox"/> EISB3155</p> <p><input type="checkbox"/> <input checked="" type="checkbox"/> <input checked="" type="checkbox"/> EISB3154</p> <p><input checked="" type="checkbox"/> <input checked="" type="checkbox"/> EISB4052</p>
<p>Metal and Texplast chair 45x59 h95 cm</p> 	<p>45x59 h95 cm</p> 	<p>↔</p> <p> 5</p>	<p> 2</p> <p> 110X43 h62 cm</p> <p> 19</p>	<p><input type="checkbox"/> <input type="checkbox"/> EISE3155</p> <p><input type="checkbox"/> <input checked="" type="checkbox"/> <input checked="" type="checkbox"/> EISE3154</p> <p><input checked="" type="checkbox"/> <input checked="" type="checkbox"/> EISE4052</p>
<p>Sunbed</p> 	<p>190x65 h35 cm</p> 	<p> 20</p>	<p> 1</p> <p> 215X72 h15 cm</p> <p> 27</p>	<p><input type="checkbox"/> <input type="checkbox"/> EILE3155</p> <p><input type="checkbox"/> <input checked="" type="checkbox"/> <input checked="" type="checkbox"/> EILE3154</p> <p><input checked="" type="checkbox"/> <input checked="" type="checkbox"/> EILE4052</p>

CLESSIDRA PAG. 40

COLLEZIONE IN TONDINO DI METALLO COMPOSTA DA DIVANO, POLTRONA, PUFF E TAVOLINO.







METAL ROD COLLECTION COMPOSED OF SOFA, CHAIR, POUF AND COFFEE TABLE.

MATERIALE / MATERIAL

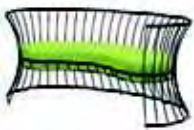
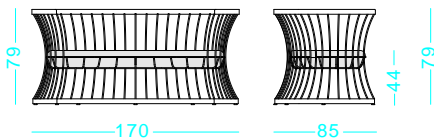
3100

CUSCINI / CUSHIONS



PRODUCT	DRAWING	INFO	PACK	ART.
2 seater sofa	170x85 h79 cm	26	1	<input type="checkbox"/> CLDI31
			175X87 h82 cm	<input checked="" type="checkbox"/> CLDI48
Seat cushion		30		
Dove grey				<input checked="" type="checkbox"/> CLCD0012
Lime				<input checked="" type="checkbox"/> CLCD0026
Armchair	70x70 h79 cm	13	1	<input type="checkbox"/> CLPO31
			77X65 h85 cm	<input checked="" type="checkbox"/> CLPO48
		15		
Pouf	diam. 63 h50 cm	10	1	<input type="checkbox"/> CLPU31
			70X70 h48 cm	<input checked="" type="checkbox"/> CLPU48
		12		
Seat cushion for armchair and pouf				
Dove grey				<input checked="" type="checkbox"/> CLCP0012
Lime				<input checked="" type="checkbox"/> CLCP0026
Coffee table	diam. 63 h41 cm	12	1	<input type="checkbox"/> CLTB3100
			70X70 h48 cm	<input checked="" type="checkbox"/> CLTB4800
		15		

ESSENZA PAG. 42

LA COLLEZIONE ESSENZA È REALIZZATA IN LEGNO DI TEAK CON INSERTI IN ACCIAIO SPAZZOLATO. È COMPOSTA DA TAVOLO, POLTRONCINE, LETTINI PRENDISOLE E LOUNGE BED CON BALDACCHINO.

THE ESSENZA COLLECTION IS MADE OF TEAK WOOD WITH BRUSHED STEEL INSERTS. IT CONSISTS OF TABLE, CHAIRS, SUNBEDS AND LOUNGE BED WITH CANOPY.

MATERIALE / MATERIAL



01



54



01



11











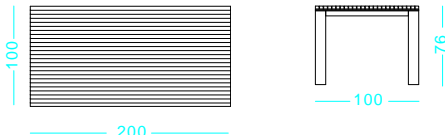

12



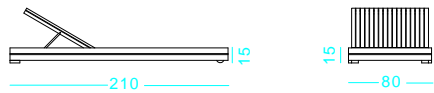

13

CUSCINI / CUSHIONS

PRODUCT	DRAWING	INFO	PACK	ART.
<p>Table</p> 	<p>200x100 h76 cm</p> 	<p>8</p> <p>76</p>	<p>1 table top</p> <p>220X110 h12 cm</p> <p>50</p> <p>1 legs</p> <p>105X78 h22 cm</p> <p>26</p>	<p>EZTR0100</p>
<p>Armchair</p> 	<p>58x56 h81 cm</p> 	<p>8</p>	<p>2</p> <p>65X65 h95 cm</p> <p>20</p>	<p>EZSB0100</p>
<p>Chair cushion</p>				<p>Ivory CUSE0001</p> <p>Green CUSE0011</p> <p>Dove grey CUSE0012</p> <p>Blue CUSE0013</p>









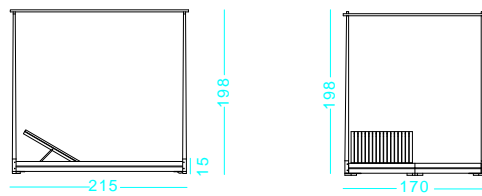

PRODUCT	DRAWING	INFO	PACK	ART.
Sun lounger	210x80 h15 cm		 1	 EZLE0100
		 40	 220X88 h18 cm	
			 44	

Mattress



Ivory	 EZMS0001
Dove grey	 EZMS0012
Blue	 EZMS0013

Double canopy sun lounger 215x170 h198 cm



	2x  1 sun lounger	 EZLB0100
 100	2x  220X88 h18 cm	
 44	2x  44	
 1 canopy poles		
 228X26 h20 cm		
 21		

Mattress

Ivory	 EZMS2P01
Dove grey	 EZMS2P12
Blue	 EZMS2P13

VILLAGE PAG. 48

COLLEZIONE IN TEAK COMPOSTA DA SALOTTO INTERO E MODULARE, TAVOLO AMPLIABILE CON PROLUNGHE, SEDIA E PANCA.











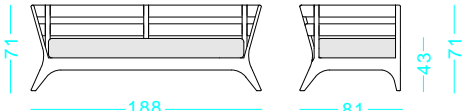











VILLAGE IS A TEAK COLLECTION COMPOSED OF ONE-PIECE AND MODULAR SOFA, EXTENDING TABLE, CHAIR AND BENCH.











































MATERIALE / MATERIAL

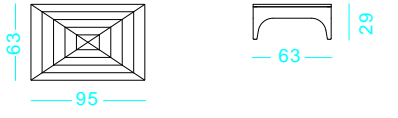

CUSCINI / CUSHIONS



PRODUCT	DRAWING	INFO	PACK	ART.
<p>3 seater sofa</p> 	<p>188x81 h71 cm</p> 	<p> 40</p> <p></p>	<p> 1</p> <p> 192X83 h73 cm</p> <p> 41</p>	<p> VIDI01</p>
Seat cushion				
Ivory				 VIDICU01
Green				 VIDICU11
Dove grey				 VIDICU12
Blue				 VIDICU13
<p>Armchair</p> 	<p>95x81 h71 cm</p> 	<p> 24</p> <p></p>	<p> 1</p> <p> 98X83 h73 cm</p> <p> 27</p>	<p> VIPO01</p>
Seat cushion				
Ivory				 VIPOCU01
Green				 VIPOCU11
Dove grey				 VIPOCU12
Blue				 VIPOCU13

PRODUCT	DRAWING	INFO	PACK	ART.
Corner module 	75x75 h71 cm 	  17 	 2  90X90 h80 cm  43	 VIAN01
Back module 	63x75 h71 cm 	  14 	 2  89X68 h80 cm  31	 VISP01
Pouf 	63x63 h27 cm 	 12	 1  70X70 h30 cm  7	 VIPU01
Seat cushion for corner, back module and pouf				
Ivory				 VICU0001
Green				 VICU0011
Dove grey				 VICU0012
Blue				 VICU0013
Square coffee table 	63x63 h29 cm 	 12	 1  70X70 h30 cm  18	 VITB0100
Rectangular coffee table 	63x95 h29 cm 	 18	 1  102X70 h30 cm  23	 VITR0100

PRODUCT	DRAWING	INFO	PACK	ART.
---------	---------	------	------	------

Square extending table 130x130 h75 cm

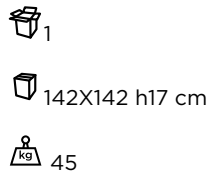
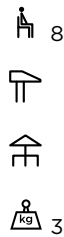
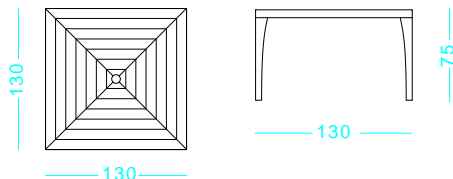

VITQ0100

Extension

4 extension leaves

224x224 cm

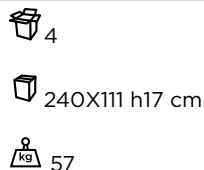
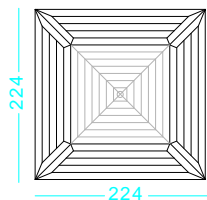

VIPR0100

TWIST turning tray

diam. 96 cm

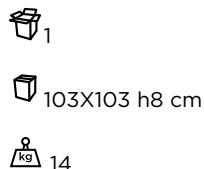

PIAG0100

Chair

51x54 h87 cm

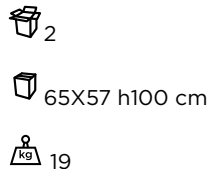

WISE0100

Chair cushion

Ivory

CUSE0001

Green

CUSE0011

Dove grey

CUSE0012

Blue

CUSE0013

Bench

159x62 h88 cm

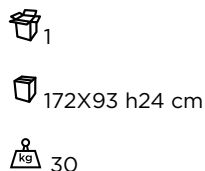
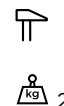
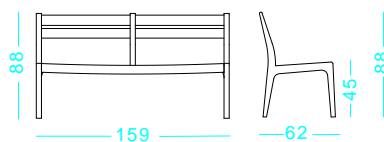

VIBE0100





CRONOS PAG. 52

TAVOLI IN TEAK CON BASE SCULTOREA E TRE DIVERSI PIANI: RETTANGOLARE ALLUNGABILE CON DOPPIA PROLUNGA, ROTONDO E QUADRATO.

TEAK TABLES WITH SCULPTED BASE AND THREE DIFFERENT TOPS: RECTANGULAR TABLE WITH DOUBLE EXTENSION, ROUND AND SQUARE.

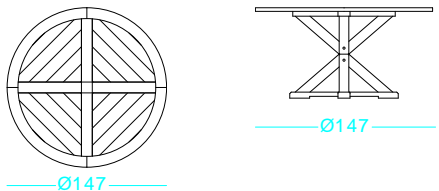
MATERIALE / MATERIAL

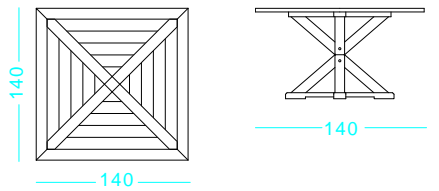

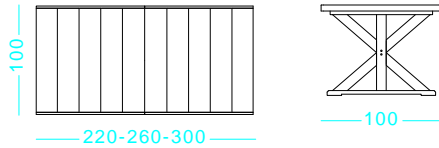
PRODUCT	DRAWING	INFO	PACK	ART.
<p>Round table</p> 	<p>diam. 147 h75 cm</p> 	<p>6-8 49</p>	<p>1 table top 153X153 h4 cm 1 base 96X87 h10 cm</p>	<p>CSTT0100</p>
<p>Square table</p> 	<p>140x140 h75 cm</p> 	<p>8 52</p>	<p>1 table top 153X153 h4 cm 1 base 96X87 h10 cm</p>	<p>CSTQ0100</p>
<p>Rectangular table</p> 	<p>220-260-300x100 h75 cm</p> 	<p>8-12 100</p>	<p>1 table top 235X116 h32 cm 1 base 182X82 h12 cm</p>	<p>CSTR0100</p>









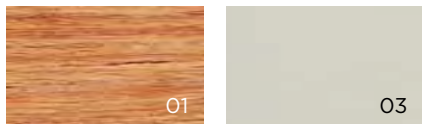

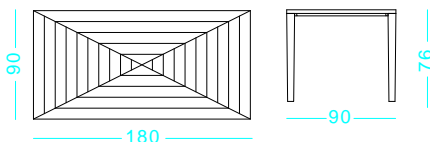







FRIENDS PAG. 54

TAVOLI LEGGERI ED ESSENZIALI, PROPOSTI IN FORMA RETTANGOLARE E QUADRATA, IN TEAK E IN MOGANO VERNICIATO.

LIGHTWEIGHT AND ESSENTIAL TABLES, AVAILABLE IN RECTANGULAR AND SQUARE SHAPE, IN TEAK AND PAINTED MAHOGANY.

MATERIALE / MATERIAL



PRODUCT	DRAWING	INFO	PACK	ART.
Rectangular table 	180x90 h76 cm 	 8   30	 1  190X97 h20 cm  38	 FRTR0100  FRTR0300
Square table 	90x90 h76 cm 	 4   18	 1  98X98 h20 cm  23	 FRTQ0100  FRTQ0300







MYA PAG. 58

POLTRONCINA IMPILABILE IN TEAK E TEXPLAST.

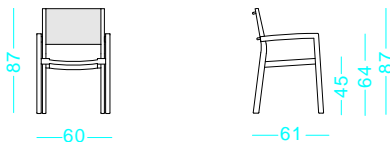
STACKABLE ARMCHAIR IN TEAK WOOD AND TEXPLAST.

MATERIALE / MATERIAL



PRODUCT	DRAWING	INFO	PACK	ART.
Armchair 	60x61 h87 cm 	 8  8	 2  68X64 h98 cm  27	 MYSB0152

AMBRA/STELLA PAG. 58

SEDIE E POLTRONCINE IMPILABILI IN TEAK NATURALE O IN MOGANO VERNICIATO.





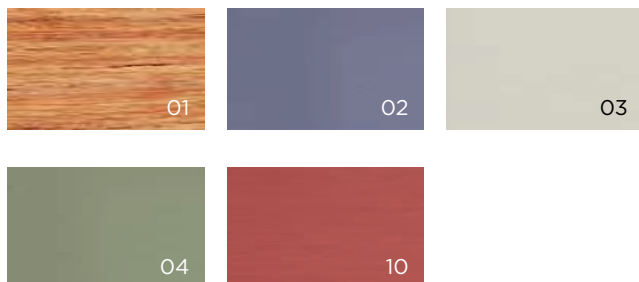





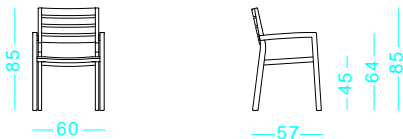







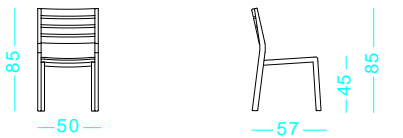

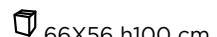

STACKABLE ARMCHAIRS OR CHAIRS IN TEAK OR PAINTED MAHOAGANY.

MATERIALE / MATERIAL

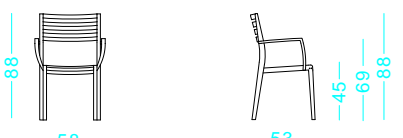



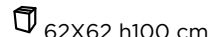

CUSCINI / CUSHIONS



PRODUCT	DRAWING	INFO	PACK	ART.
AMBRA armchair 	60x57 h85 cm 	  10	 2  68X68 h100 cm  28	 AMSB0100
AMBRA chair 	50x57 h85 cm 	  7	 2  66X56 h100 cm  22	 AMSE0100
STELLA armchair 	58x53 h88 cm 	  6	 2  62X62 h100 cm  18	STMT

Chair cushion

Ivory	 CUSE0001
Green	 CUSE0011
Dove grey	 CUSE0012
Blue	 CUSE0013

NOTTING HILL PAG. 60

PANCA DA GIARDINO PROPOSTA IN TEAK CON FINITURA DECAPATA O IN MOGANO VERNICIATO.





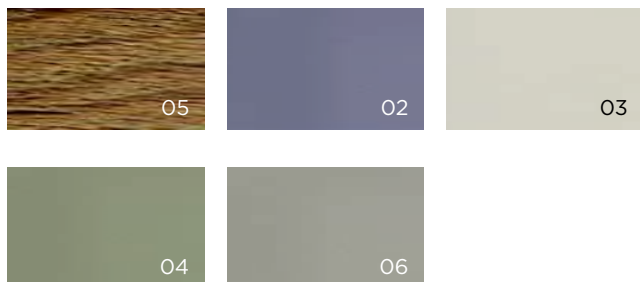





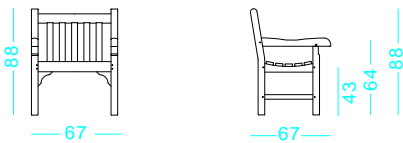

GARDEN BENCH IN PICKLED TEAK OR PAINTED MAHOGANY.

MATERIALE / MATERIAL

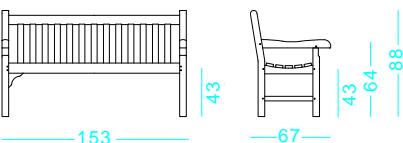

CUSCINI / CUSHIONS



PRODUCT	DRAWING	INFO	PACK	ART.
<p>Armchair</p> 	<p>67x67 h88 cm</p> 	  16	 1  93X70 h20 cm  18	<p>NHPM</p>
<p>Seat cushion</p> <p>Ivory</p>				<p>NHCC0001</p>
<p>Bench</p> 	<p>153x67 h88 cm</p> 	  25	 1  190X75 h20 cm  29	<p>NHDM</p>
<p>Seat cushion 2 pieces</p> <p>Ivory</p>				<p>NHCL0001</p>

CRUISE PAG. 62

CHAISE LONGUE IN TEAK O IN MOGANO
VERNICIATO CON DETTAGLI IN OTTONE E
SCHIENALE REGOLABILE.

DECK CHAIR IN NATURAL TEAK WOOD OR
PAINTED MAHOGANY WITH BRASS DETAILS
AND ADJUSTABLE BACKREST.

MATERIALE / MATERIAL

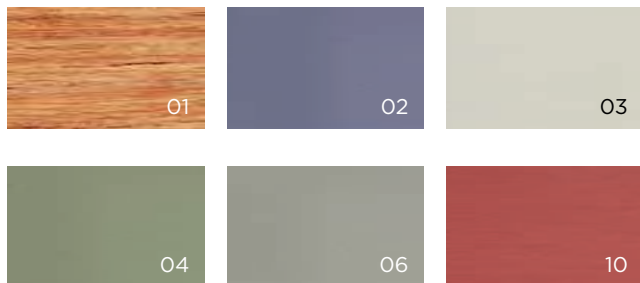

CUSCINI / CUSHIONS

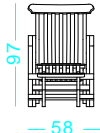
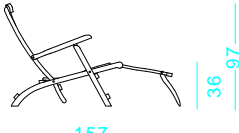

PRODUCT	DRAWING	INFO	PACK	ART.
Deck chair	157x58 h97 cm	→ ← ✂ ⚖ 16	📦 1 📦 130X64 h23 cm ⚖ 20	CRMT
				
Mattress				
Ivory				CRCL0001





















PETIT CLUB / CLUB PAG. 65

TAVOLINI MULTIUSO CON VASSOIO ESTRAIBILE, PROPOSTI IN TEAK O IN MOGANO VERNICIATO.

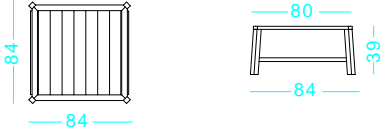
MULTIPURPOSE TABLES WITH REMOVABLE TRAY, AVAILABLE IN TEAK OR PAINTED MAHOGANY.

MATERIALE / MATERIAL



PRODUCT	DRAWING	INFO	PACK	ART.
Square coffee table 	54x54 h39 cm 	  7	 1  64X58 h24 cm  10	PCQM
Rectangular coffee table 84x54 h39 cm 		  11	 1  90X58 h24 cm  14	PCRM
CLUB coffee table 84X84 h39 cm 		  15	 1  90X90 h26 cm  20	 CLTQ0100

LETTINO PRENDISOLE E SDRAIO PIEGHEVOLE
IN TEAK CON TELO IN TESSUTO ACRILICO O
IN TEXPLAST IN DIFFERENTI COLORI.

FOLDING TEAK SUNBED AND DECK CHAIR
WITH ACRYLIC OR TEXPLAST FABRIC COVER IN
DIFFERENT COLOURS.

MATERIALE / MATERIAL



01

ACRYLYC



12

TEXPLAST



50



51



52



54

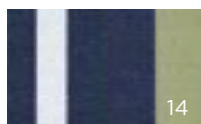

14













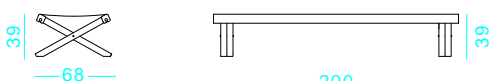

53

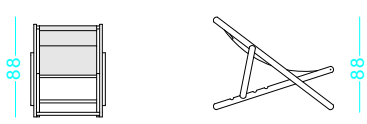

54



56

PRODUCT	DRAWING	INFO	PACK	ART.
<p>ELÌT sunbed</p> 	<p>68x200 h39 cm</p> 	<p>→ ←</p> <p> 10</p>	<p> 1</p> <p> 210X83 h15 cm</p> <p> 18</p>	<p>ETLE01</p>
<p>ELLE deck chair</p> 	<p>100x62 h88 cm</p> 	<p>→ ←</p> <p></p> <p> 6</p>	<p> 1</p> <p> 130X70 h10 cm</p> <p> 9</p>	<p>ELSD01</p>

SAND PAG. 70

LETTINO PRENDISOLE IN TEAK E TEXPLAST CON SCHIENALE REGOLABILE.







SUNBED IN TEAK AND TEXPLAST WITH ADJUSTABLE BACKREST.

MATERIALE / MATERIAL

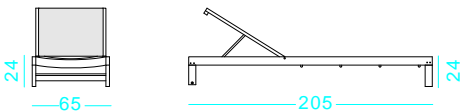

TEXPLAST



PRODUCT	DRAWING	INFO	PACK	ART.
<p>Sunbed</p> 	<p>205x65 h24 cm</p> 	   19	 1  215X72 h13 cm  23	<p>SDLE01</p>

SANDY PAG. 72

SCHIENALE IN TEAK REGOLABILE.







TEAK ADJUSTABLE BACKREST.

MATERIALE / MATERIAL

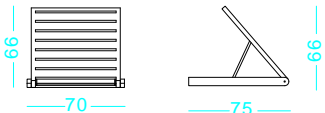

TEXPLAST



PRODUCT	DRAWING	INFO	PACK	ART.
<p>Backrest</p> 	<p>185x70 h15-66 cm</p> 	  7	 1  85X77 h11 cm  9	<p> SYPS0100</p>

Texplast mattress

Dove grey

 SYMS0052

Striped

 SYMS0054

SAHARA PAG. 74

LETTINO PRENDISOLE IN TEAK CON SUPERFICIE ANATOMICA E SCHIENALE REGOLABILE.







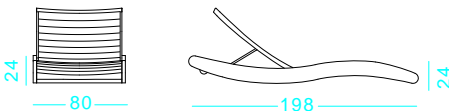

TEAK SUN LOUNGER WITH ANATOMICAL SURFACE AND ADJUSTABLE BACKREST.

MATERIALE / MATERIAL



MATERASSINO / MATTRESS



PRODUCT	DRAWING	INFO	PACK	ART.
<p>Sun lounger</p> 	<p>198x80 h24 cm</p> 	  31	 1  206X88 h25 cm  39	 SHLE0100
<p>Mattress</p> <hr/> <p>Ivory</p>				 SHCLO001







ECLIPSE PAG. 58

BAULE PORTAOGGETTI DI TEAK CON PARETI LATERALI A PERSIANA.

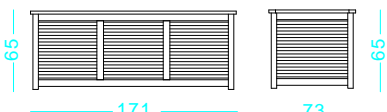
TEAK TRUNK WITH LOUVERED SIDE WALLS.

MATERIALE / MATERIAL



PRODUCT	DRAWING	INFO	PACK	ART.
<p>Trunk</p> 	<p>171x73 h65 cm</p> 	  48	 1  184X86 h30 cm  64	 ECBA0100

PHORMA PAG. 76

SALOTTO IN FIBRA ETWICK INTRECCIATA A MANO CON FINITURA RUVIDA, DISPONIBILE IN DUE TONALITÀ NATURALI, CORTECCIA E BIANCO.









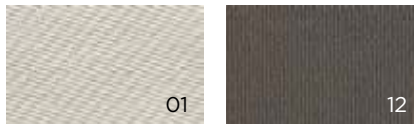

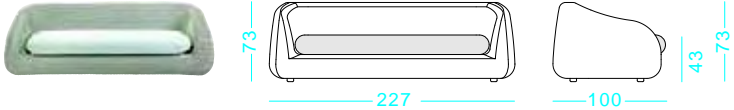

SOFA AND ARMCHAIR IN HANDWOVEN ETWICK FIBER WITH ROUGH FINISH, AVAILABLE IN TWO NATURAL COLOURS, BARK AND WHITE.

MATERIALE / MATERIAL

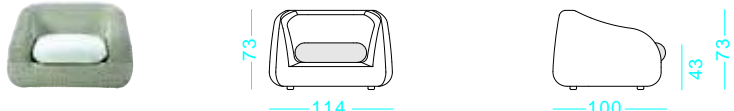

CUSCINI / CUSHIONS



PRODUCT	DRAWING	INFO	PACK	ART.
3 seater sofa	227x100 h73 cmm 	 48 	 1  230X102 h76 cm  52	<input type="checkbox"/> PHDI21 <input checked="" type="checkbox"/> PHDI20
Seat cushion				
Ivory				<input checked="" type="checkbox"/> PHCD0001
Dove grey				<input checked="" type="checkbox"/> PHCD0012
Armchair	114x100 h73 cm 	 23 	 1  115X100 h76 cm  29	<input type="checkbox"/> PHPO21 <input checked="" type="checkbox"/> PHPO20
Seat cushion				
Ivory				<input checked="" type="checkbox"/> PHCP0001
Dove grey				<input checked="" type="checkbox"/> PHCP0012

ROYAL PAG. 78

SALOTTO IN FIBRA ETWICK INTRECCIATA A MANO CON FINITURA RUVIDA, DISPONIBILE IN COLORE CORTECCIA.









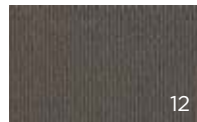

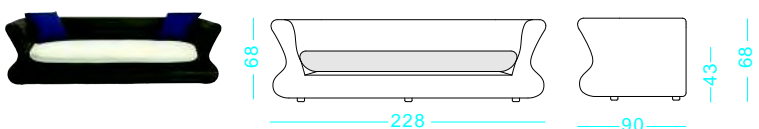







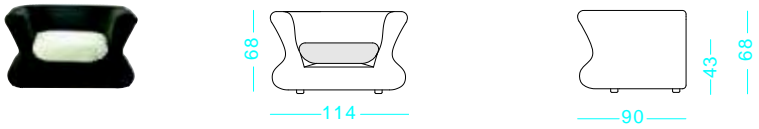





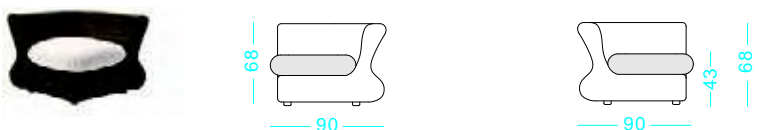

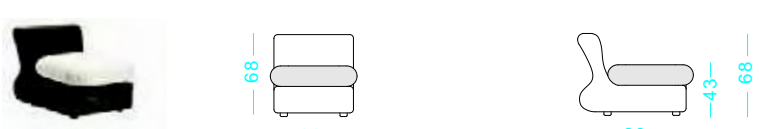

SOFA AND ARMCHAIR IN HANDWOVEN ETWICK FIBER WITH ROUGH FINISH, AVAILABLE IN BARK COLOUR.

MATERIALE / MATERIAL



CUSCINI / CUSHIONS



PRODUCT	DRAWING	INFO	PACK	ART.
3 seater sofa	228x90 h68 cm 	 41 	 1  230X102 h76 cm  53	 RLDI20
Seat cushion				
Ivory				 RLDICU01
Dove grey				 RLDICU12
Armchair	114x90 h68 cm 	 21 	 1  115X100 h76 cm  27	 RLPO20
Corner module	90x90 h68 cm 	 21 	 1  92X92 h76 cm  24	 RLAN20
Back module	66x90 h68 cm 	 15 	 1  92X72 h76 cm  18	 RLSP20
Seat cushion				
Ivory				 RLSPCU01
Dove grey				 RLSPCU12

CUBE PAG. 84

COLLEZIONE IN FIBRA ETWICK INTRECCIATA A MANO CON FINITURA RUVIDA COMPOSTA DA SALOTTO INTERO E MODULARE, PUFF, LETTINO PRENDISOLE, DISPONIBILE IN DUE TONALITÀ NATURALI, CORTECCIA E BIANCO.









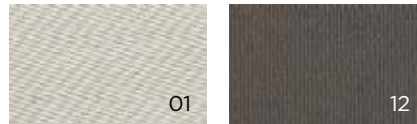

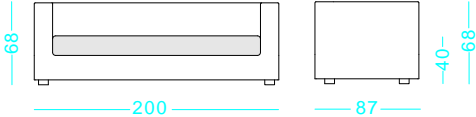







COLLECTION IN HANDWOVEN ETWICK FIBER WITH ROUGH FINISH COMPOSED OF ONE-PIECE AND MODULAR SOFA, POUF, SUNBED, AVAILABLE IN TWO NATURAL COLOURS, BARK AND WHITE.

MATERIALE / MATERIAL



CUSCINI / CUSHIONS



PRODUCT	DRAWING	INFO	PACK	ART.
3 seater sofa 	200x87 h68 cm 	 36 	 1  203X89 h70 cm  43	<input type="checkbox"/> CBDI21 <input checked="" type="checkbox"/> CBDI20
Seat cushion				
Ivory				<input checked="" type="checkbox"/> CBDICU01
Dove grey				<input checked="" type="checkbox"/> CBDICU12
Armchair 	101x87 h68 cm 	 21 	 1  105X90 h70 cm  24	<input type="checkbox"/> CBPO21 <input checked="" type="checkbox"/> CBPO20
Seat cushion				
Ivory				<input checked="" type="checkbox"/> CBPOCU01
Dove grey				<input checked="" type="checkbox"/> CBPOCU12
Coffee table 	87x87 h23 cm 	 9	 1  88X88 h28 cm  11	<input type="checkbox"/> CBTB2100 <input checked="" type="checkbox"/> CBTB2000

PRODUCT	DRAWING	INFO	PACK	ART.
Corner module 	87x87 h68 cm 	  19 	 1  90X90 h70 cm  22	<input type="checkbox"/> CBAN21 <input checked="" type="checkbox"/> CBAN20
Back module 	71x87 h68 cm 	  15 	 1  90X90 h70 cm  18	<input type="checkbox"/> CBSP21 <input checked="" type="checkbox"/> CBSP20
Seat cushion				
Ivory				<input checked="" type="checkbox"/> CBSPCU01
Dove grey				<input checked="" type="checkbox"/> CBSPCU12
Sunbed 	210x81 h27 cm 	  35 	 1  215X85 h35 cm  38	<input type="checkbox"/> CBLE21 <input checked="" type="checkbox"/> CBLE20
Mattress				
Ivory				<input checked="" type="checkbox"/> CBLECU01
Dove grey				<input checked="" type="checkbox"/> CBLECU12
Pouf 	43x43 h42 cm 	 6	 1  48X48 h48 cm  7	<input type="checkbox"/> CBPU2100 <input checked="" type="checkbox"/> CBPU2000

MOON PAG. 88

LOUNGE BED COMPOSTO DA DUE ELEMENTI
UTILIZZABILI ANCHE SINGOLARMENTE, DISPONIBILE
IN DUE TONALITÀ NATURALI, CORTECCIA E BIANCO.

LOUNGE BED COMPOSED OF TWO ELEMENTS,
AVAILABLE IN TWO NATURAL COLOURS,
BARK AND WHITE.

MATERIALE / MATERIAL



CUSCINI / CUSHIONS



PRODUCT	DRAWING	INFO	PACK	ART.
Lounge bed diameter	240 h45 cm	37	2X 1	<input type="checkbox"/> MOLD21
			2X 245X125 h48 cm	<input checked="" type="checkbox"/> MOLD20
			2X 42	
Seat cushion				
Ivory				<input checked="" type="checkbox"/> MOCU0001
Dove grey				<input checked="" type="checkbox"/> MOCU0012
Blue				<input checked="" type="checkbox"/> MOCU0013

LOTO PAG. 78

TAVOLINI IN FIBRA ETWICK INTRECCIATA
A MANO CON FINITURA RUVIDA.

COFFEE TABLES IN HANDWOVEN ETWICK
FIBER WITH ROUGH FINISH.

MATERIALE / MATERIAL



PRODUCT	DRAWING	INFO	PACK	ART.
Rectangular coffee table	65x40 h25 cm	5	1	<input type="checkbox"/> LOTR2100
			67X42 h29 cm	<input checked="" type="checkbox"/> LOTR2000
			6	
Square coffee table	90x90 h25 cm	9	1	<input type="checkbox"/> LOTQ2100
			91X91 h28 cm	<input checked="" type="checkbox"/> LOTQ2000
			12	

TIME PAG. 90

POLTRONCINA AVVOLGENTE E TAVOLO QUADRATO CON LATI ARROTONDATI IN FIBRA ETWICK INTRECCIATA A MANO CON FINITURA RUVIDA.

















WRAP-AROUND ARMCHAIR AND SQUARE TABLE WITH ROUNDED SIDES IN HANDWOVEN ETWICK FIBER WITH ROUGH FINISH.

MATERIALE / MATERIAL

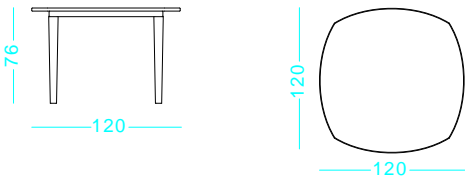

CUSCINI / CUSHIONS



PRODUCT	DRAWING	INFO	PACK	ART.
<p>Armchair</p> 	<p>61x67 h88 cm</p> 	<p> 14</p>	<p> 1</p> <p> 71X64 h92 cm</p> <p> 17</p>	<p> TMPO20</p>
<p>Seat cushion</p>				<p> TMCU0001</p> <p> TMCU0012</p>
<p>Square table</p> 	<p>120x120 h76 cm</p> 	<p> 4</p> <p> 23</p>	<p> 1</p> <p> 125X125 h18 cm</p> <p> 26</p>	<p> TMTQ2000</p>

DEHORS

OMBRELLONE DI DIMENSIONI COMPATTE
CON STRUTTURA IN ALLUMINIO E TELO IN
POLIESTERE BIANCO.

COMPACT UMBRELLA WITH ALUMINIUM FRAME AND
WHITE POLYESTER CANVAS.

MATERIALE / MATERIAL







52

TELI/ CANVAS

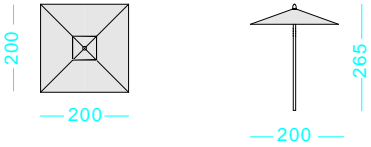

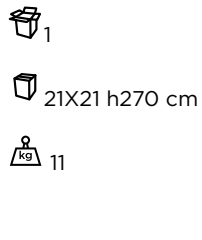
07

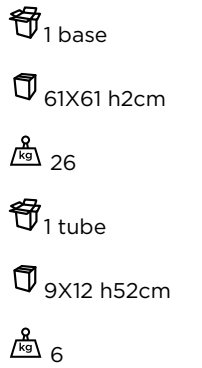
PRODUCT	DRAWING	INFO	PACK	ART.
<p>Square umbrella</p> 	<p>200x200 h265 cm</p> 			<p><input type="checkbox"/> DHOMQU07</p>
<p>Base</p> <p>30 kg</p>	<p>60x60 h35cm</p> 			<p><input type="checkbox"/> OMBF311P</p> <p><input checked="" type="checkbox"/> OMBF401P</p>

FREE PAG. 92

OMBRELLONI CON STRUTTURA IN ALLUMINIO, CORONA DI TEAK, CARRUCOLA PER APERTURA E CHIUSURA E TELI DI DIVERSI COLORI.

ALUMINIUM UMBRELLAS WITH TEAK CROWN, PULLEY FOR OPENING AND CLOSING AND CANVAS OF DIFFERENT COLOURS.

MATERIALE / MATERIAL



52





TELI/ CANVAS





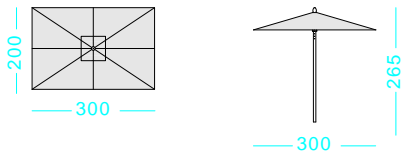

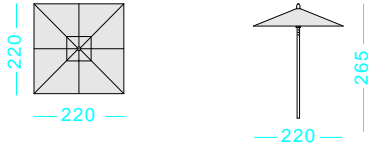

















07



09

PRODUCT	DRAWING	INFO	PACK	ART.
<p>Rectangular umbrella</p> 	<p>300x200 h265 cm</p> 	<p>↔</p> <p>☂</p> <p>☀</p> <p>⚖ 10</p>	<p>📦 1</p> <p>📦 21X21 h270 cm</p> <p>⚖ 12</p>	<p>☐ UMFERE07</p> <p>■ UMFERE09</p>
<p>Square umbrella</p> 	<p>220x220 h265 cm</p> 	<p>↔</p> <p>☂</p> <p>☀</p> <p>⚖ 9</p>	<p>📦 1</p> <p>📦 21X21 h270 cm</p> <p>⚖ 11</p>	<p>☐ UMFEQP07</p> <p>■ UMFEQP09</p>
Base				
<p>30 kg</p>	<p>60x60 h35cm</p> 	<p>📦</p> <p>⚖ 30</p>	<p>📦 1 base</p> <p>📦 61X61 h2 cm</p> <p>⚖ 26</p> <p>📦 1 tube</p> <p>📦 9X12 h52cm</p> <p>⚖ 6</p>	<p>☐ OMBF311P</p> <p>■ OMBF401P</p>

PRODUCT	DRAWING	INFO	PACK	ART.
Square umbrella	350x350 h280 cm	   	 1  23X23 h305 cm  19	<input type="checkbox"/> UMFEQG07 <input checked="" type="checkbox"/> UMFEQG09
Base				
55 kg	60x60 cm	  55	 1 base  61X61 h 2cm  26  1 tube  9X12 h52cm  6	<input type="checkbox"/> OMBA312P <input checked="" type="checkbox"/> OMBA402P
80 kg	60x60 cm	  80	 1 base  61X61 h2 cm  26  1 tube  9X12 h52cm  6	<input type="checkbox"/> OMBA313P <input checked="" type="checkbox"/> OMBA403P

LIBERTY

OMBRELLONE CON PALO LATERALE IN ACCIAIO INOX, CORONE IN TEAK, CARRUCOLA PER APERTURA E CHIUSURA.

SIDE ARM PATIO STAINLESS STEEL UMBRELLA, TEAK CROWNS AND PULLEY FOR OPENING AND CLOSING.

MATERIALE / MATERIAL



53

TELI/ CANVAS



07

PRODUCT	DRAWING	INFO	PACK	ART.
Rectangular umbrella	400x300 h320 cm	 280	1 umbrella 30X30 h294 cm 51 1 base* 109X109 h33 cm 40	LYOMBR07
<p>* Base for LYOMBR07 and OMBR50 / OMBL50</p> <div style="display: flex; justify-content: space-around; align-items: center;"> <div style="text-align: center;"> <p>102</p> <p>102</p> </div> <div style="text-align: center;"> <p>46</p> <p>102</p> </div> </div>				
<div style="display: flex; justify-content: space-between; align-items: center;"> <div style="text-align: center;"> <p>8 cement tiles 50x50 h4 cm</p> 8X 25 </div> <div style="text-align: center;"> <p>2X 4</p> <p>2X 50X50 h60cm</p> 204 </div> <div style="text-align: center;"> <p>SETMA8LY</p> </div> </div>				

HOLIDAY PAG. 94











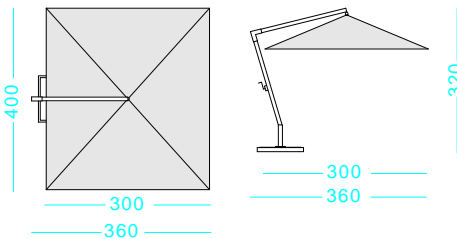























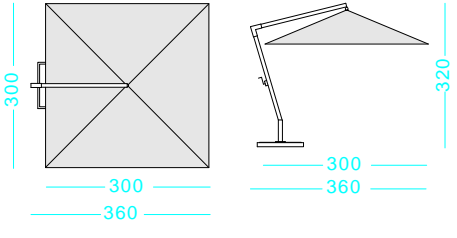













OMBRELLONI CON PALO LATERALE IN LEGNO E BASE IN METALLO. DOTATO DI CARRUCOLA PER APERTURA E CHIUSURA, HA TELI IN DIVERSI COLORI.

SIDE ARM PATIO WOODEN UMBRELLAS WITH METAL BASE. EQUIPPED WITH A PULLEY TO OPEN AND CLOSE IT, AND COVERS IN DIFFERENT COLOURS.

MATERIAL

TELI/ CANVAS



PRODUCT	DRAWING	INFO	PACK	ART.
Rectangular umbrella	400x300 h320 cm 	    285	 1 umbrella  23X23 h280 cm  24  2 poles  34X13 h280 cm  32  1 base*  109X109 h33 cm  40	 OMBR5008  OMBR5010  OMBR5011  OMBR5012  OMBR5013
8 cement tiles 50x50 h4 cm	 2X  25  204	 4  50X50 h60cm  204	SETMA8PZ	
Square umbrella	300x300 h320 cm 	    275	 1 umbrella  23X23 h265 cm  21  2 poles  34X13 h280 cm  32  1 base*  109X109 h33 cm  40	 OMBL5008  OMBL5010  OMBL5011  OMBL5012  OMBL5013
8 cement tiles 50x50 h4 cm	 2X  25  204	 4  50X50 h60cm  204	SETMA8PZ	

CLASSIC PAG. 95

OMBRELLONI CON STRUTTURA IN LEGNO,
CARRUCOLA PER APERTURA E CHIUSURA E
TELI IN DIVERSI COLORI.





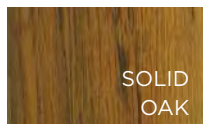



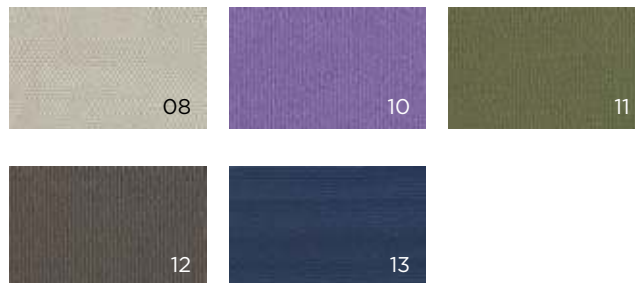

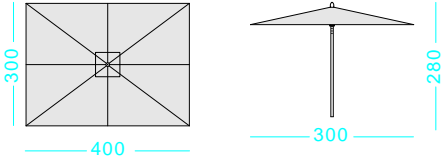













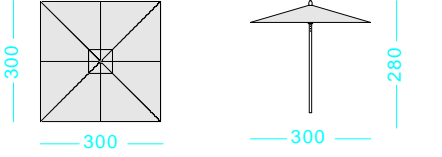

UMBRELLAS WITH WOODEN FRAME, PULLEY
FOR OPENING AND CLOSING AND CANVAS IN
DIFFERENT COLOURS.











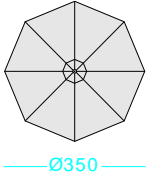
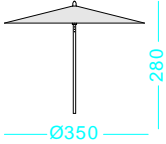











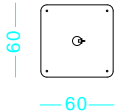
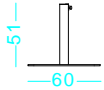









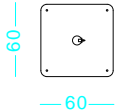







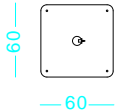
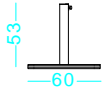

MATERIALE / MATERIAL



TELI/ CANVAS



PRODUCT	DRAWING	INFO	PACK	ART.
Rectangular umbrella 	400x300 h280 cm 	   	  	 OMRESB08  OMRESB10  OMRESB11  OMRESB12  OMRESB13
Square umbrella 	300x300 h280 cm 	   	  	 OMQTSB08  OMQTSB10  OMQTSB11  OMQTSB12  OMQTSB13

PRODUCT	DRAWING	INFO	PACK	ART.
Round umbrella 	diam. 350 h280 cm  	    19	 1  26X26 h280 cm  21	 OMROSB08  OMROSB10  OMROSB11  OMROSB12  OMROSB13
Base				
30 kg	60x60 cm  	 30	 1 base  61X61 h2cm  26  1 tube  9X12 h52cm  6	 OMBA311P  OMBA401P
55 kg	60x60 cm  	 55	2x  1 base 2x  61X61 h2cm 2x  26  1 tube  9X12 h52cm  6	 OMBA312P  OMBA402P
80 kg	60x60 cm  	 80	3x  1 base 3x  61X61 h2cm 3x  26  1 tube  9X12 h52cm  6	 OMBA313P  OMBA403P

SQUARE PAG. 96

GAZEBO 4X4 METRI IN I-TEAK PROPOSTO CON DIVERSE COPERTURE. I-TEAK È UN NUOVO MATERIALE PROGETTATO DA ETHIMO CHE UNISCE LE CARATTERISTICHE DEL TEAK A QUELLE DEL METALLO, DANDO VITA AD UN PRODOTTO ESTREMAMENTE RESISTENTE E VERSATILE.

GAZEBO 4X4 METERS IN I-TEAK, PROPOSED WITH DIFFERENT COVERS. I-TEAK IS A NEW MATERIAL DESIGNED BY ETHIMO THAT COMBINES THE FEATURES OF TEAK TO THOSE OF THE METAL, RESULTING IN AN EXTREMELY DURABLE AND VERSATILE PRODUCT.

MATERIALE / MATERIAL

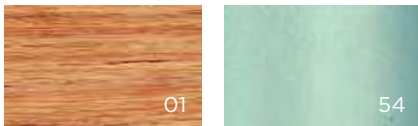

TENDE / CURTAINS

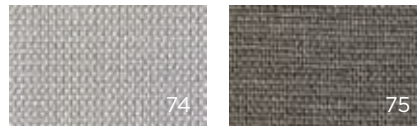

PRODUCT	DRAWING	INFO	PACK	ART.
Gazebo with cover in teak slats 400x400 h240 cm		240	1 120X90 h350 cm 260	SQGC01CT
Gazebo with PVC cover 400x400 h300 cm		220	1 180X120 h350 cm 240	SQGC01CP
Curtains kit				
White velum	8 curtains x 150x200 cm			<input type="checkbox"/> KITT4474
Grey velum	8 curtains x 150x200 cm			<input checked="" type="checkbox"/> KITT4475

FLAIR PAG. 98

FIORIERA PORTAVASO IN MOGANO VERNICIATO
DISPONIBILE IN DUE DIMENSIONI.

PAINTED MAHOGANY PLANTER AVAILABLE
IN TWO SIZES.

MATERIALE / MATERIAL

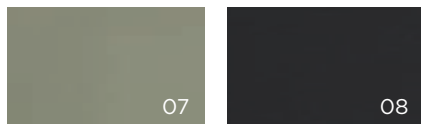































MATÌ PAG. 99

FIORIERA IN TEAK O MOGANO VERNICIATO,
RETTANGOLARE O QUADRATA, CON VASCA
INTERNA IN LAMIERA.

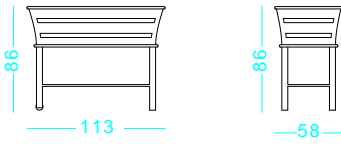
TEAK OR MAHOGANY PAINTED PLANTER IN
DIFFERENT SHAPES, WITH INSIDE METAL BOX.

MATERIALE / MATERIAL



PRODUCT	DRAWING	INFO	PACK	ART.
FLAIR planter 	50x50 h50 cm 	 15	 1  55X55 h55 cm  18	 FA50LE07  FA50LE08
FLAIR XL planter 	65x65 h60 cm 	 20	 1  70X70 h70 cm  23	 FA65LE07  FA65LE08
MATÌ square planter 	58x58 h86 cm 	 21	 1  63X63 h50 cm  24	 FIQU01VA  FIQU04VA
MATÌ rectangular planter 113x58 h86 cm 	113x58 h86 cm 	 32	 1  121X63 h50 cm  35	 FIRTO1VA  FIRTO4VA









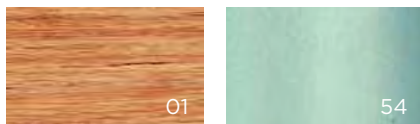















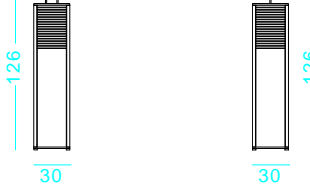

GINGER PAG. 100

LAMPADA CON STRUTTURA IN ALLUMINIO E LAMELLE DI TEAK PROPOSTA IN TRE VARIANTI E IN DIVERSE DIMENSIONI: DA TERRA ALTA E BASSA E DA MURO.

LAMP WITH ALUMINIUM FRAME AND TEAK SLATS AVAILABLE IN THREE VARIANTS AND DIFFERENT SIZES: TALL AND SMALL FLOOR AND WALL LAMP.

MATERIALE / MATERIAL



PRODUCT	DRAWING	INFO	PACK	ART.
Wall lamp 	20x12 h40 cm 	 2	 1 22X14 h42 cm  3	 GGLM0100
Electrical informations				
   IP43 1 x 12W E14 MAX 12W 220-240V				
Floor lamp 	20x20 h51 cm 	 4	 1 22X22 h53 cm  5	 GGLT0100
Electrical informations				
   IP64 1 x E27 MAX 20W FL 220-240V				
XL Floor lamp 	30x30 h126 cm 	 8	 1 32X32 h130 cm  10	 GGLG0100
Electrical informations				
   IP64 1 x E27 MAX 20W FL 220-240V				

TOUR PAG. 103

LAMPADA SEGNAPASSO IN TERRACOTTA SMALTATA
CON DIFFUSORE IN VETRO TRASPARENTE.
ADATTA A LAMPADE A RISPARMIO ENERGETICO.

CYLINDRICAL PATH LAMP IN GLAZED TERRACOTTA
WITH TRANSPARENT GLASS DIFFUSER.
SUITABLE FOR ENERGY SAVING LAMPS.

MATERIALE / MATERIAL



PRODUCT	DRAWING	INFO	PACK	ART.
Cylindrical path lamp	diam 17 h30 cm	4	1	<input type="checkbox"/> TOUR6000
			19X19 h32 cm	<input type="checkbox"/> TOUR6100
			7	<input type="checkbox"/> TOUR6200
				<input type="checkbox"/> TOUR6300

Electrical informations

IP64 1 x GU10 MAX 11W FL 220-240V

STEP PAG. 102

LAMPADA SEGNAPASSO IN TERRACOTTA
DI FORMA QUADRATA. ADATTA A LAMPADE A
RISPARMIO ENERGETICO.

SQUARE PATH LAMP IN TERRACOTTA. SUITABLE FOR
ENERGY SAVING LAMPS.

MATERIALE / MATERIAL

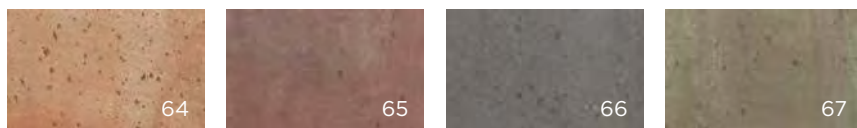

PRODUCT	DRAWING	INFO	PACK	ART.
Square path lamp	17x17 h30 cm	5	1	<input type="checkbox"/> STEP6400
			19X19 h32 cm	<input type="checkbox"/> STEP6500
			9	<input type="checkbox"/> STEP6600
				<input type="checkbox"/> STEP6700

Electrical informations

IP64 1 x GU10 MAX 11W FL 220-240V

CUSHIONS PAG. 104

CUSCINI SCHIENALE DECORATIVI.

DECORATIVE AND COMPLEMENTARY THROW PILLOWS.

MATERIALE / MATERIAL



PRODUCT	DRAWING	INFO	PACK	ART.
COMFORT	45x45 h18 cm	 	 1  46X46 h18 cm  1	CUCTQU X CUCTQU26
COMFORT	63x45 h18 cm	 	 1  46X46 h18 cm  1.5	CUCTRE X CUCTRE26
RELAX	45x45 h12 cm	 	 2  46X46 h18 cm  1.5	CURX2P
DESIGN	40x40 h15 cm	 	 2  46X46 h18 cm  1.5	CUDEQU25 CUDEQU24 CUDEQU28

X 26 not available



WHITESENCE s.r.l. Via Brisa 16 - 20123 Milano - ITALIA

info@ethimo.com • + 39 0761 300 444 • SHOWROOM MILAN corso Magenta

Copyright Whitesence - total or partial reproduction of text, photos and illustrations is not allowed, unless authorized.
Photographers: Frédéric Vasseur, Dario Fusaro and Mauro Mattioli.



WWW.ETHIMO.COM



Tel +39 0761 300 444
e-mail info@ethimo.com