

101

C O P E N H A G E N



Nama Dining Chair, Coffee Black - Linen

Designed by

Kristian Sofus Hansen &
Tommy Hyldahl

Nama Dining Chair, Coffee Black - Linen

Product Description

Inspired by traditional Japanese stick chairs, the Nama Dining Chair blends raw simplicity with refined craftsmanship. Its name - Nama, meaning "raw" and "natural" in Japanese - reflects its minimalist design, where every curved wooden element serves a structural purpose.

The dining chair is lightweight, elegant, and durable. A distinctive upholstered backrest, inspired by Copenhagen bicycle bags and secured with simple straps, adds comfort and visual appeal, complemented by a fully upholstered seat both in a beautiful sand coloured linen. The frame made in Oak with a Coffee Black finish, the Nama dining chair balances organic warmth, bold contrast, and soft elegance.

The Nama Dining Chair is ideal for use around dining tables or workspaces where its sculptural lines and comfortable upholstered seat can be appreciated. Pair several chairs together for a cohesive dining setting, or use individually as an accent seating option to highlight its refined craftsmanship and elegant silhouette.

Designer Description

Tommy Hyldahl and Kristian Sofus Hansen intertwine their distinct sensibilities to create designs where storytelling, materiality, and timeless form meet in quiet harmony.

With a background in fashion, Tommy brings an intuitive eye for trends, colors, and textures. His process is one of layering histories, blending details and references from past design periods and reimagining them into something fresh and contemporary. Each collection unfolds as a narrative, evolving from concept to creation, with every element contributing to a greater story.

Kristian, who has lived and studied in Japan, seeks to unite Japanese aesthetics with Danish design, creating a characteristic twist on simplicity itself. His work is defined by the search for subtle, original details that elevate each piece with a unique signature. Drawing inspiration from art and sculpture, his creative process unfolds in new and exciting ways, always striving to craft designs that are both functional and timeless.

Together, they craft design that transcends time, poetic yet practical, expressive yet enduring.



Nama Dining Chair, Coffee Black - Linen

Main

SKU	253092	Product Family	Nama
Product name	Nama Dining Chair, Coffee Black - Linen	Color	Coffee Black Oak & Linen 8047-2
Product Type	Dining Chair	Size	Regular
		Unit	Piece

Logistics

EAN number	4251501414483	Package - CBM	0.235
Package height in cm	82.00	Package - Weight KG	8.600
Package width in cm	55.00	Tariff Code No	9401690090
Package length in cm	52.00	Country of origin	China
Suitable for Courier	Yes	Quantity of Inner Boxes	1

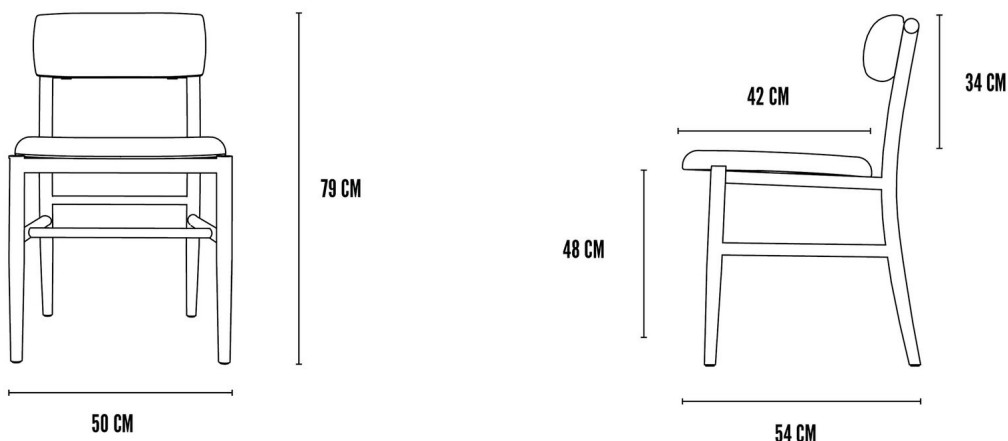

Nama Dining Chair, Coffee Black - Linen

Product

Materials	Oak & Linen	Net weight in kg	5
Item Height in cm	79.50	Space Suitability	Indoor
Item width in cm	54.00	Strength Test	L1
Item length in cm	50.00	FSC Wood	Yes

Upholstery

Fabric	Linen 8047-2	Cigarette Test - CAL-117	No
Martindale	18.000	Cigarette Test - EN 1021-1	No
Colour Fastness to Light	N/A	Cigarette Test - BS5852 Part 1	No
Pilling	N/A	Match Flame Test - EN 1021-2	No
Oeko Tex	N/A	Ignition Source 5 (Crib 5) - BS 5852 Part 2	No
Fire Test Foam	CAL-117	NF P92-507 - Class M1	No

Nama Dining Chair, Coffee Black - Linen

Family Description Text

The Nama Series is a meditation on simplicity, inspired by the quiet elegance of traditional Japanese stick chairs, where nothing is superfluous and every detail carries intention. Its name, Nama, meaning "raw" and "natural" in Japanese, reflects a philosophy of honesty: in materials, in form, in the way each piece invites you to pause and inhabit the present.

Shaped by hand and guided by restraint, the chairs balance lightness and strength in a sculptural yet unassuming silhouette. Curved wooden lines soften into harmony, while the upholstered backrest, fastened with two simple straps and recalling the effortless functionality of Copenhagen bicycle bags, introduces a touch of tactility and character. Together with the cushioned seat, it creates a subtle embrace, offering comfort without excess.

The series flows seamlessly between lounge and dining, private and public, intimacy and gathering. It is furniture that does not demand attention, but quietly rewards it, objects that age with grace, carrying the mark of craftsmanship and the warmth of use.

Color Description

This combination balances the profound depth of Coffee Black Oak with the raw, sandy beige tone of Linen 8047-2. The oak's near-black intensity anchors the pairing, while the linen introduces warmth, softness, and natural texture. Together, they create a dialogue of contrast dark and light, smooth and tactile expressing timeless elegance with a modern edge.

Nama Dining Chair, Coffee Black - Linen

Maintenance Guide Description

This furniture combines the enduring strength of American Red Oak with the natural softness of linen. Both materials are living surfaces that age beautifully with time, and each requires thoughtful care to preserve its character.

For American Red Oak, dust regularly with a soft, dry cloth. For deeper cleaning, wipe gently with a slightly damp cloth in the direction of the grain, then dry immediately. Avoid abrasive cleaners, silicone-based polishes, or excess water, which may damage the surface. Protect oak surfaces with coasters, mats, or felt pads, and wipe spills promptly to prevent staining. Keep the wood away from direct sunlight, heat sources, and extreme humidity to maintain stability and prevent fading.

For linen upholstery, vacuum gently with a soft brush attachment to remove dust and prevent particles from embedding in the fibers. In case of spills, blot immediately with a clean, dry cloth never rub, as this may spread the stain or push liquid deeper into the weave. For light stains, use a mild upholstery cleaner suitable for natural fabrics, always testing it first on an inconspicuous area. Professional upholstery cleaning is recommended for deeper care. Protect linen from prolonged exposure to direct sunlight and excessive humidity to preserve its color and texture.

With regular care, the harmony of oak's grounded strength and linen's organic softness will grow richer with age, ensuring a lasting balance of resilience, comfort, and natural beauty.

Materials Description

This pairing unites the grounded strength of American Red Oak with the natural softness of linen. FSC-certified and responsibly sourced, the oak reveals its story through every grain tight, resilient, and warm in tone maturing over time into a rich patina that reflects years of use and care. Its stability allows for sculptural shaping, where bold lines and soft curves highlight the material's raw elegance.

Balancing this strength, linen offers a tactile warmth and organic character. Woven from natural fibers, it is celebrated for its durability, subtle texture, and timeless comfort. Over time, linen softens and develops a lived-in beauty that enhances both touch and appearance.

Together, American Red Oak and linen create furniture that is both sculptural and inviting an interplay of resilience and softness, structure and comfort crafted to age gracefully and grow more personal with each passing year.