

101

C O P E N H A G E N



Nama Dining Chair - Nubuck

Designed by

Kristian Sofus Hansen &
Tommy Hyldahl

Nama Dining Chair - Nubuck

Product Description

Inspired by traditional Japanese stick chairs, the Nama Dining Chair blends raw simplicity with refined craftsmanship. Its name - Nama, meaning "raw" and "natural" in Japanese - reflects its minimalist design, where every curved wooden element serves a structural purpose.

The dining chair is lightweight, elegant, and durable. A distinctive upholstered backrest, inspired by Copenhagen bicycle bags and secured with simple straps, adds comfort and visual appeal, complemented by a fully upholstered seat both in a beautiful Nubuck leather. The frame made in natural oak, the Nama dining chair balances organic warmth, bold contrast, and soft elegance.

The Nama Dining Chair is ideal for use around dining tables or workspaces where its sculptural lines and comfortable upholstered seat can be appreciated. Pair several chairs together for a cohesive dining setting, or use individually as an accent seating option to highlight its refined craftsmanship and elegant silhouette.

Designer Description

Tommy Hyldahl and Kristian Sofus Hansen intertwine their distinct sensibilities to create designs where storytelling, materiality, and timeless form meet in quiet harmony.

With a background in fashion, Tommy brings an intuitive eye for trends, colors, and textures. His process is one of layering histories, blending details and references from past design periods and reimagining them into something fresh and contemporary. Each collection unfolds as a narrative, evolving from concept to creation, with every element contributing to a greater story.

Kristian, who has lived and studied in Japan, seeks to unite Japanese aesthetics with Danish design, creating a characteristic twist on simplicity itself. His work is defined by the search for subtle, original details that elevate each piece with a unique signature. Drawing inspiration from art and sculpture, his creative process unfolds in new and exciting ways, always striving to craft designs that are both functional and timeless.

Together, they craft design that transcends time, poetic yet practical, expressive yet enduring.



Nama Dining Chair - Nubuck

Main

SKU	253090	Product Family	Nama
Product name	Nama Dining Chair - Nubuck	Color	Natural Oak & Nude Nubuck
Product Type	Dining Chair	Size	Regular
		Unit	Piece

Logistics

EAN number	4251501414469	Package - CBM	0.235
Package height in cm	82.00	Package - Weight KG	8.600
Package width in cm	55.00	Tariff Code No	9401690090
Package length in cm	52.00	Country of origin	China
Suitable for Courier	Yes	Quantity of Inner Boxes	1

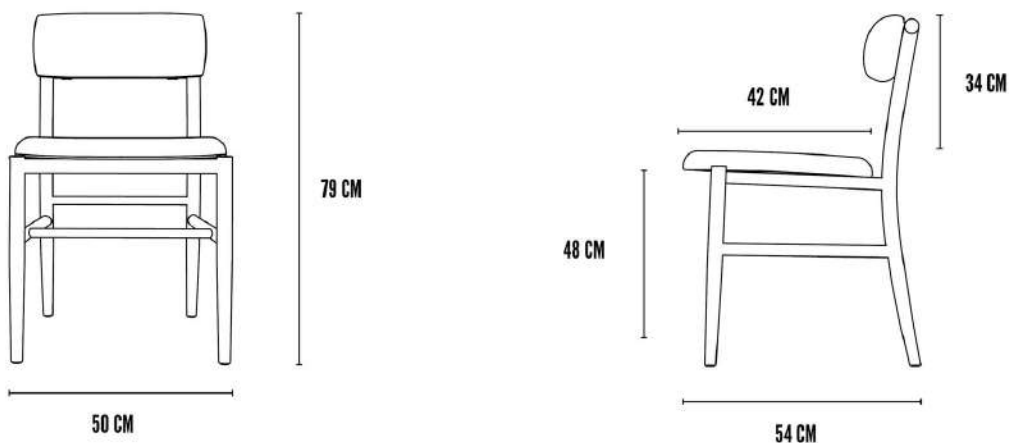

Nama Dining Chair - Nubuck

Product

Materials	Oak & Nubuck	Net weight in kg	5
Item Height in cm	79.50	Space Suitability	Indoor
Item width in cm	54.00	Strength Test	L1
Item length in cm	50.00	FSC Wood	Yes

Upholstery

Fabric	Nubuck Leather (NU30)	Cigarette Test - CAL-117	No
Martindale	50.000	Cigarette Test - EN 1021-1	Yes
Colour Fastness to Light	3	Cigarette Test - BS5852 Part 1	No
Pilling	5.000 Rubs	Match Flame Test - EN 1021-2	No
Oeko Tex	N/A	Ignition Source 5 (Crib 5) - BS 5852 Part 2	No
Fire Test Foam	CAL-117	NF P92-507 - Class M1	No

Nama Dining Chair - Nubuck

Family Description Text

The Nama Series is a meditation on simplicity, inspired by the quiet elegance of traditional Japanese stick chairs, where nothing is superfluous and every detail carries intention. Its name, Nama, meaning "raw" and "natural" in Japanese, reflects a philosophy of honesty: in materials, in form, in the way each piece invites you to pause and inhabit the present.

Shaped by hand and guided by restraint, the chairs balance lightness and strength in a sculptural yet unassuming silhouette. Curved wooden lines soften into harmony, while the upholstered backrest, fastened with two simple straps and recalling the effortless functionality of Copenhagen bicycle bags, introduces a touch of tactility and character. Together with the cushioned seat, it creates a subtle embrace, offering comfort without excess.

The series flows seamlessly between lounge and dining, private and public, intimacy and gathering. It is furniture that does not demand attention, but quietly rewards it, objects that age with grace, carrying the mark of craftsmanship and the warmth of use.

Color Description

This combination brings together the golden warmth of American Red Oak with the soft, natural tone of Nude Nubuck. The oak's subtle reddish undertones harmonize with the beige neutrality of the nubuck, creating a palette that feels both authentic and inviting. Together, they embody natural elegance, wooden strength paired with velvety softness, timeless, versatile, and refined.

Nama Dining Chair - Nubuck

Maintenance Guide Description

This furniture combines the enduring strength of American Red Oak with the velvety tactility of Nubuck leather. Both are natural materials that evolve with use and time, requiring mindful care to preserve their beauty.

For American Red Oak, dust regularly with a soft, dry cloth. Clean occasionally with a slightly damp cloth, always wiping in the direction of the grain, and dry immediately. Avoid abrasive cleaners, polishes with silicone, or excess water, as these can damage the finish or raise the grain. To protect surfaces, always use coasters, mats, or felt pads under objects, and wipe spills promptly to prevent staining. Keep the wood away from direct sunlight, heat sources, and extreme humidity to maintain stability and prevent fading.

For Nubuck upholstery, brush gently and regularly with a soft nubuck brush to lift the nap and prevent dirt from embedding. Avoid contact with water, oils, or sharp objects, as Nubuck is sensitive to staining and scratching. In case of spills, blot immediately with a clean, dry cloth never rub, as this can push liquid deeper into the hide. Light marks may be treated with a nubuck cleaning block, while more persistent stains should be handled by a professional leather specialist. Keep Nubuck away from direct sunlight and heat to avoid fading and drying.

With attentive care, the combination of oak's grounded strength and Nubuck's tactile softness will develop a rich patina, growing more personal and characterful over the years.

Materials Description

Our furniture unites the strength of American Red Oak with the velvety tactility of Nubuck leather. FSC-certified and responsibly sourced, the oak carries the quiet resilience of the forests it comes from. Its tight grain and natural stability make it ideal for sculptural forms, while its warm tones and textured surface ground each piece with a refined, timeless presence. Over time, the wood matures gracefully, developing a rich patina that reflects years of use and care.

Balanced against this enduring strength, Nubuck introduces a soft, suede-like touch, lightly sanded to achieve its velvety, matte surface. Subtle tonal variations and natural markings bring individuality, while its sensitivity to wear allows it to develop a unique patina, becoming more personal with every interaction.

Together, American Red Oak and Nubuck create a dialogue between resilience and refinement hard and soft, structured and tactile resulting in furniture that is both sculptural and sensorial, evolving beautifully with time.