

# 101

C O P E N H A G E N



**Nama Dining Chair, Coffee Black - Aniline leather black**

Designed by

Kristian Sofus Hansen &  
Tommy Hyldahl

# Nama Dining Chair, Coffee Black - Aniline leather black

---

## Product Description

Inspired by traditional Japanese stick chairs, the Nama Dining Chair blends raw simplicity with refined craftsmanship. Its name - Nama, meaning "raw" and "natural" in Japanese - reflects its minimalist design, where every curved wooden element serves a structural purpose.

The dining chair is lightweight, elegant, and durable. A distinctive upholstered backrest, inspired by Copenhagen bicycle bags and secured with simple straps, adds comfort and visual appeal, complemented by a fully upholstered seat both in a beautiful Black Aniline Leather. The frame made in Oak with a Coffee Black finish, the Nama dining chair balances organic warmth, bold contrast, and soft elegance.

The Nama Dining Chair is ideal for use around dining tables or workspaces where its sculptural lines and comfortable upholstered seat can be appreciated. Pair several chairs together for a cohesive dining setting, or use individually as an accent seating option to highlight its refined craftsmanship and elegant silhouette.

## Designer Description

Tommy Hyldahl and Kristian Sofus Hansen intertwine their distinct sensibilities to create designs where storytelling, materiality, and timeless form meet in quiet harmony.

With a background in fashion, Tommy brings an intuitive eye for trends, colors, and textures. His process is one of layering histories, blending details and references from past design periods and reimagining them into something fresh and contemporary. Each collection unfolds as a narrative, evolving from concept to creation, with every element contributing to a greater story.

Kristian, who has lived and studied in Japan, seeks to unite Japanese aesthetics with Danish design, creating a characteristic twist on simplicity itself. His work is defined by the search for subtle, original details that elevate each piece with a unique signature. Drawing inspiration from art and sculpture, his creative process unfolds in new and exciting ways, always striving to craft designs that are both functional and timeless.

Together, they craft design that transcends time, poetic yet practical, expressive yet enduring.

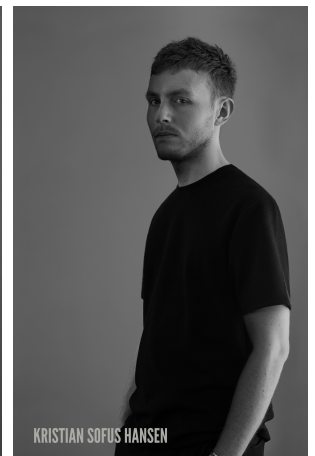

# Nama Dining Chair, Coffee Black - Aniline leather black

## Main

SKU	253094	Product Family	Nama
Product Name	Nama Dining Chair, Coffee Black - Aniline leather black	Color	Coffee Black Oak & Aniline Leather Black
Product Type	Dining Chair	Size	Regular
		Unit	Piece

## Logistics

EAN number	4251501414506	Package - CBM	0.235
Package height in cm	82.00	Package - Weight KG	8.600
Package width in cm	55.00	Tariff Code No	9401690090
Package length in cm	52.00	Country of origin	China
Suitable for Courier	Yes	Quantity of Inner Boxes	1

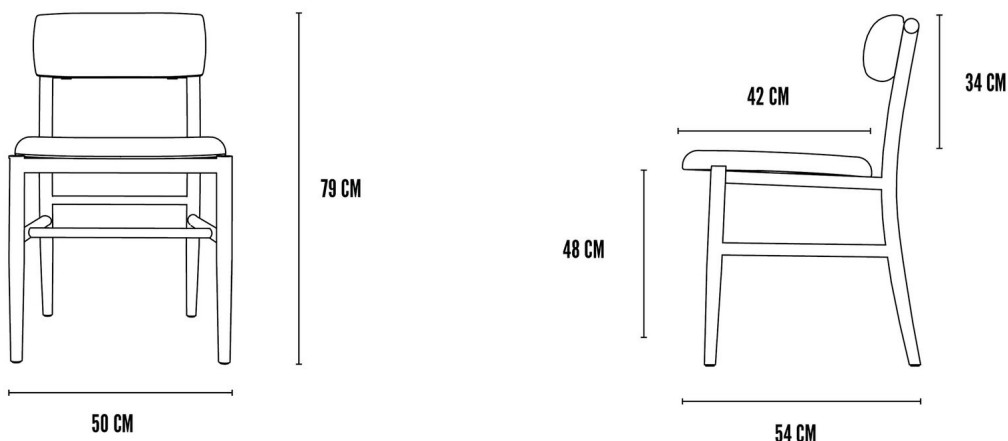

# Nama Dining Chair, Coffee Black - Aniline leather black

---

## Product

Materials	Oak & Aniline Leather	Net weight in kg	5
Item Height in cm	79.50	Space Suitability	Indoor
Item width in cm	54.00	Strength Test	L1
Item length in cm	50.00	FSC Wood	Yes

## Upholstery

Fabric	Aniline Leather YH-002#	Cigarette Test - CAL-117	No
Martindale	50.000	Cigarette Test - EN 1021-1	Yes
Colour Fastness to Light	5	Cigarette Test - BS5852 Part 1	No
Pilling	N/A	Match Flame Test - EN 1021-2	No
Oeko Tex	N/A	Ignition Source 5 (Crib 5) - BS 5852 Part 2	No
Fire Test Foam	CAL-117	NF P92-507 - Class M1	No

# Nama Dining Chair, Coffee Black - Aniline leather black

---

## Family Description Text

The Nama Series is a meditation on simplicity, inspired by the quiet elegance of traditional Japanese stick chairs, where nothing is superfluous and every detail carries intention. Its name, Nama, meaning "raw" and "natural" in Japanese, reflects a philosophy of honesty: in materials, in form, in the way each piece invites you to pause and inhabit the present.

Shaped by hand and guided by restraint, the chairs balance lightness and strength in a sculptural yet unassuming silhouette. Curved wooden lines soften into harmony, while the upholstered backrest, fastened with two simple straps and recalling the effortless functionality of Copenhagen bicycle bags, introduces a touch of tactility and character. Together with the cushioned seat, it creates a subtle embrace, offering comfort without excess.

The series flows seamlessly between lounge and dining, private and public, intimacy and gathering. It is furniture that does not demand attention, but quietly rewards it, objects that age with grace, carrying the mark of craftsmanship and the warmth of use.

## Color Description

This pairing unites the profound depth of Coffee Black Oak with the refined richness of black aniline leather. The oak's nearly black tone, warmed by subtle brown undertones, resonates with the leather's velvety surface, creating a monochrome palette of intensity and elegance. Together, they express strength and sophistication--timeless, bold, and grounded.

# Nama Dining Chair, Coffee Black - Aniline leather black

---

## Maintenance Guide Description

This furniture combines the enduring strength of American Red Oak with the natural richness of aniline leather. Both are living materials that age gracefully, developing a patina that reflects years of use and care.

For American Red Oak, dust regularly with a soft, dry cloth. Clean occasionally with a slightly damp cloth, always wiping in the direction of the grain, and dry immediately. Avoid abrasive cleaners, silicone-based polishes, or excess water, as these can damage the finish or raise the grain. Protect surfaces with coasters, mats, or felt pads, and wipe spills promptly to prevent staining. Keep the wood away from direct sunlight, heat sources, and high humidity to maintain stability and prevent fading.

For aniline leather, dust or vacuum regularly with a soft brush attachment. Because the leather is untreated and highly absorbent, spills should be blotted immediately with a clean, dry cloth--never rubbed, as this may spread liquid or leave marks. Avoid water, oils, solvents, and household cleaners, which can damage the surface. Over time, occasional conditioning with a high-quality leather care product will help maintain suppleness and prevent drying. Keep the leather away from direct sunlight and heat to avoid fading or cracking.

With mindful care, the combination of oak's grounded strength and aniline leather's natural depth will grow more personal with time, embodying elegance, warmth, and authenticity.

## Materials Description

This pairing unites the grounded strength of American Red Oak with the natural richness of aniline leather. FSC-certified and responsibly sourced, the oak reveals its story through every grain tight, resilient, and warm in tone maturing over time into a rich patina that reflects years of use and care. Its stability allows for sculptural shaping, where bold lines and soft curves highlight the material's raw elegance.

Complementing this strength, aniline leather embodies authenticity and tactility. Lightly treated to preserve the hide's natural surface, it displays unique markings and tonal variations while offering a supple touch. Over time, it develops a deep, personal patina that enriches both comfort and character.

Together, American Red Oak and aniline leather create furniture that is both sculptural and sensorial an interplay of resilience and softness, precision and warmth crafted to age beautifully and grow more individual with each passing year.